

DURABILITY, WARRANTY, MAINTENANCE

PRODUCT TECHNICAL STATEMENT

(a) Statement of Building Code Compliance

NZBC Compliance

Test information available from Pacific Coilcoaters and BHP NZ Steel, and past history of fascia systems, indicate that provided the product use and maintenance is in line with the guidelines contained in the current literature referenced, Dimond Rainwater Disposal Systems can be expected to meet the performance criteria in clause E2 of the New Zealand Building Code, for a period of not less than 5 years.

Use Outside the Stated Guidelines

If the need arises to use Dimond Rainwater Disposal Systems outside the limitations and procedures given in this or other referenced literature, or, if any doubt exists on product handling or use, written approval for use must be obtained from Dimond, before the project commences.

(b) Scope of Use

Dimond Fascia 147, 165 Paltec, F180 and 185 are coated steel fascia systems intended for use as fascia and barge boards to support gutter systems, covering roof truss ends and gable ends around the roof perimeter on timber trussed residential buildings. External gutters are then fixed directly to the fascia to allow collection and discharge of rainwater.

Suitable for use with longrun metal roofing, metal tiles or concrete tiled roofs. Reference should be made to Section 2.1.1.2 Environments, to ensure the correct coated material on the fascia is chosen for the environment.

Dimond do not recommend fascia systems are used in very severe marine or geothermal environments as fascia is not available in plain aluminium, AR8, ARX, stainless steel or copper. Tradition timber fascia should be used in these environments.

Typically 185 panel is used up the gable ends while 147 panel is used along the front.

165 Paltec fascia is an older very distinct profile with a wide foot. F180 is a modern 180 deep slim profile.

(c) Consenting Instructions

Metal fascia systems have been used successfully on timber trussed residential buildings for the last 20 years.

For consenting it is important to check the correct prepainted finish has been selected for the environment. Refer to Section 2.1.1.2.

The gutter size should be chosen for its water carrying capacity in accordance with Section 3.1.4 and should ensure the size of the bracket and gutter can physically fit the panel depth with correct overflow allowances.

DESCRIPTION

Dimond coated steel fascia systems are available in 147mm, 165 Paltec, F180 and 185mm high panel, roll formed in 0.55mm BMT Zincalume® with a prepainted finish only. Unpainted Zincalume® product, copper, stainless steel and aluminium are not available.

The outer edge of the soffit lining is retained at the bottom of the fascia in a rolled Soffit groove.

DESIGN INSTRUCTIONS

- The set out of the fascia support brackets are shown in the construction details in Section 3.4.4.
- Level or sloping soffits up to 22.5° pitch can be used.
- When installing Fascia rafter brackets for a shingle roof over ply on top of the rafters the set out is

	Dimension "B"*
147 Fascia Panel	145
185 Fascia Panel	175

Using these dimensions allows for a 10-12mm gap between the fascia and underside of the ply
 * Refer to section 3.4.4 for the location of Dimension "B"

- Brackets are nailed or screw fixed to the soffit bearer or rafters when sloping soffits are used.
- The recommended set out heights must be maintained to avoid birds and vermin entering the roof space.
- Steel products should not come into contact with concrete and must avoid dissimilar metal contact.
- When selecting the gutter to use with the fascia system it is important to:
 - i) Consider the catchment area for each downpipe draining into the gutter (called flow load) to ensure the capacity of the gutter (called flow capacity) has not been exceeded. Refer to Section 3.1.4 for the method.
 - ii) Ensure the gutter with bracket can physically fit onto the fascia vertical face, laid to a fall of a minimum 1:500 and give an acceptable appearance. If not, select another smaller gutter size.

CONSTRUCTION INSTRUCTIONS

Selection of metal fascias needs to be made before the trusses are manufactured as the set out dimension may vary between the different systems available.

- Builders must ensure the timber soffit bearers are correctly set out using the published guidelines for the roof type being used prior to the fascia installation.
- Fascia brackets are nailed or screwed onto the soffit bearers to a level and true alignment using a string line.
- 6m maximum length of fascia are then fitted to the fascia brackets, cut back in length where necessary, and lengths joined together using normal roofing practice with silicone sealant and 4mm diameter rivets at 150mm maximum centres. Corner soaker caps are fitted over the fascias and rivetted on to cover corner joints or can be mitred cut.
- Metal fascia are specialised system that require specialised installers. Metal roofers do not normally install fascia.
- We do not recommend, support or approve DIY installations. Specialist companies throughout New Zealand install Dimond fascia. Contact Dimond for a list of installers in your area. Phone 0800 DIMOND (0800 346 663).

FASCIA 147 AND 165 PALTEC INSTALLATION GUIDE

Metal Tiles and Metal Roofs

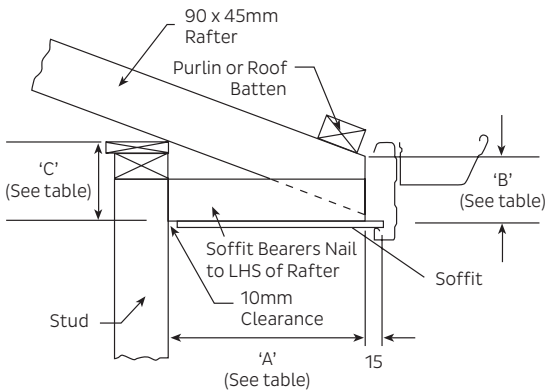

Hip & Gable Roof - Eaves Detail

Soffit Width (mm)	300	450	600	750	900
Dimension 'A' (mm)	295	445	595	745	895

Notes:

- A 10mm soffit clearance has been allowed for:
- Soffit bearers fixed to LEFT hand side of rafter (viewed from outside).
- Based on minimum Purlin/Roof batten thickness of 45mm.

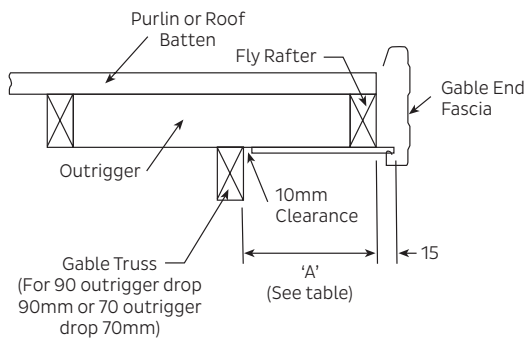

Gable End Detail

Soffit Width (mm)	300	450	600
Dimension 'A' (mm)	295	445	595

Note:

Fascia brackets must be fitted to all rafters. The installation of gutter brackets and snow straps in snow areas is to be as per section 3.1.4.7 of the Dimond manual. Snow areas N4 and N5 require 5 fasteners per Rafter bracket.

Roof Pitch (Degrees)	Drop Heights - Dimensions 'C' (mm) *See note 8										Dim. 'B' Toe Cut 147 Cable end	'B' Toe Cut Paltec
	Soffit Width (mm)											
	300		450		600		750		900			
	147	165 Paltec	147	165 Paltec	147	165 Paltec	147	165 Paltec	147	165 Paltec		
10	60	73	86	100	113	127	139	154	165	184	95	92
12.5	72	87	105	121	138	155	171	189	205	223	95	93
15	87	101	127	142	167	183	208	224	248	265	96	96
17.5	98	115	145	163	192	211	240	259	287	307	96	94
20	113	129	167	184	222	239	277	294	331	349	97	96
22.5	129	145	191	205	253	265	315	325	377	385	101	96
25	142	155	212	225	282	295	352	365	422	435	105	100
30	170	189	257	275	344	361	430	447	516	533	109	104
35	206	220	311	325	416	430	521	535	626	640	116	112
40	247	253	373	380	499	507	625	635	751	762	122	118
45	280	293	420	442	580	591	730	740	880	889	129	125

Notes for Installers

1. To ensure birds cannot enter the roof space, there should be no gap between the bottom purlin and the back face of the gutter after the system has been installed.
2. The 147 small panel fascia system is suitable for use with metal tiles and roofs with sloping soffits up to 22.5° roof pitch.
3. Over 25° roof pitch, a kickout may be required on all gable ends.
4. As an alternative to note 3, for gable end roofs, outriggers to be from finished timber sizes 70mm x 45mm i.e. gable end truss drop 70mm, avoiding kickouts up to 40° roof pitch.
5. NOTE: Soffit bearers are required on all hip corners and should be cut back 20mm to all free movement of the spouting.
6. Zincolume® coated gutters should have a minimum fall of at least 1:500 and should not have permanent ponding.
7. Where loose fill insulation is used, the soffit must be blocked off at the top plate to prevent the insulation coming into contact with the metal fascia. Check with your nearest distributor for further details.
8. Allows for a 16-18mm gap for easy fascia panel removal. If gap is not required dimensions will need to be altered.

FASCIA 147 AND 165 PALTEC INSTALLATION GUIDE

Concrete Tile Roofs

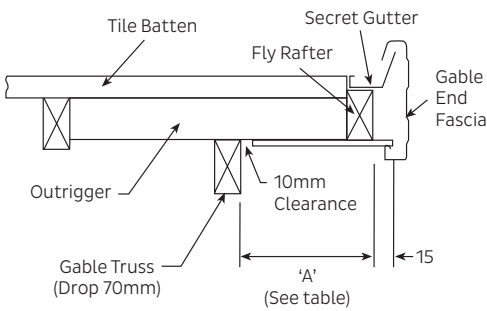
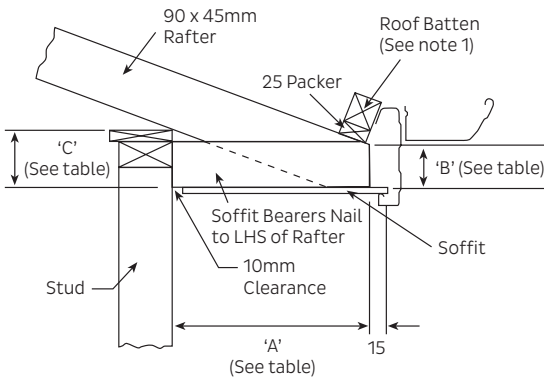

Hip & Gable Roof – Eaves Detail

Soffit Width (mm)	300	450	600
Dimension 'A' (mm)	295	445	595

Notes:

- A 10mm soffit clearance has been allowed for:
- Soffit bearers fixed to LEFT hand side of rafter (viewed from outside).
- Based on minimum Purlin/Roof batten thickness of 47mm.

Gable End Detail

Soffit Width (mm)	300	450	600
Dimension 'A' (mm)	295	445	595

Notes:

- Finished timber sizes
- Outriggers 70mm x 45mm
- Fly rafter 90mm x 45mm

Fascia brackets must be fitted to all rafters. The installation of gutter brackets and snow straps in snow areas is to be as per section 3.1.4.7 of the Dimond manual. Snow areas N4 and N5 require 5 fasteners per Rafter bracket.

Roof Pitch (Degrees)	Drop Heights - Dimensions 'C' (mm) *See note 8										Dim 'B' Toe Cut 147	Dim 'B' Toe Cut Paltec
	Soffit Width (mm)											
	300		450		600		750		900			
	147	165 Paltec	147	165 Paltec	147	165 Paltec	147	165 Paltec	147	165 Paltec		
17.5	72	109	119	162	166	209	213	260	261	309	85	95
20	84	125	141	185	195	238	250	295	305	352	88	96
22.5	101	138	163	202	226	267	288	332	350	396	91	99
25	117	155	187	227	257	300	327	373	397	445	95	100
30	150	181	237	268	323	355	410	441	497	528	100	104
35	187	220	292	327	397	435	502	544	607	651	112	111
40	227	251	353	378	479	502	605	628	731	756	124	118
45	275	285	425	430	575	574	725	719	875	836	135	125

Notes for Installers

1. To ensure birds cannot enter the roof space, there should be no gap between the bottom purlin and the back face of the gutter after the system has been installed.
2. The 147 small panel fascia is not suitable on concrete tile roofs with sloping soffits.
3. For concrete tile gable end roofs, outriggers to be from finished timber sizes 70mm x 45mm i.e. gable end truss drop 70mm.
4. Over 25° roof pitch, a kickout is required on all gable ends.
5. NOTE: Soffit bearers are required on all hip corners and should be cut back 20mm to allow free movement of the spouting.
6. Zinalume® coated gutters should have a minimum fall of at least 1:500 and should not have permanent ponding.
7. Where loose fill insulation is used, the soffit must be blocked off at the top plate to prevent the insulation coming into contact with the metal fascia. Check with your nearest distributor for further details.
8. Allows for a 16-18mm gap for easy fascia panel removal. If gap is not required dimensions will need to be altered.

FASCIA 185 AND F180 INSTALLATION GUIDE

Metal Tiles and Metal Roofs

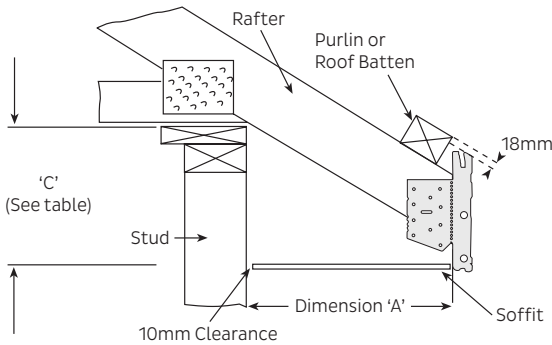

Hip & Gable Roof – Eaves Detail

Soffit Width (mm)	300	450	600
Dimension 'A' (mm)	295	445	595

Notes:

- 90x45 soffit bearer used unless stated.
- Soffit bearers fixed to right or left hand side of rafter.
- 10mm clearance allowed for soffit.

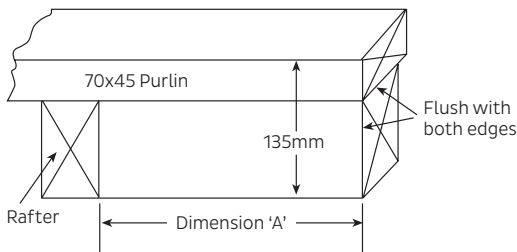

Gable End Detail

Soffit Width (mm)	300	450	600
Dimension 'A' (mm)	295	445	595

Note:

Fascia brackets must be fitted to all rafters. The installation of gutter brackets and snow straps in snow areas is to be as per section 3.1.4.7 of the Dimond manual. Snow areas N4 and N5 require 5 fasteners per Rafter bracket.

Roof Pitch (Degrees)	Drop Heights - Dimensions 'C' (mm)							
	Soffit Width (mm)							
	300		450		600		750	
	185	F180	185	F180	185	F180	185	F180
10	95	85	123	114	151	143	179	172
12.5	107	100	140	136	173	172	206	208
15	120	115	160	157	200	199	240	241
17.5	133	125	180	175	227	225	274	275
20	145	142	200	199	254	256	309	313
22.5	160	155	222	220	284	285	346	350
25	173	170	243	244	313	318	383	392
27.5	188	185	266	268	344	351	422	434
30	202	205	289	296	376	387	463	478
35	233	235	338	342	443	449	548	556
40	268	268	394	394	520	520	646	646
45	306	305	456	456	606	607	756	758
50	350	350	529	529	708	708	887	887

Notes for Installers

1. To ensure birds cannot enter the roof space, there should be no gap between the bottom purlin and the back face of the gutter after the system has been installed.
2. NOTE: Soffit bearers are required on all hip corners and should be cut back 10mm.
3. Where loose fill insulation is used, the soffit must be blocked off at the top plate to prevent the insulation coming into contact with the metal fascia.
4. Zincolume® coated gutters should have a minimum fall of at least 1:500 and should not have permanent ponding. Check with your nearest distributor for further details.

FASCIA 185, F180 & GUTTER INSTALLATION GUIDE

Concrete Tile Roofs

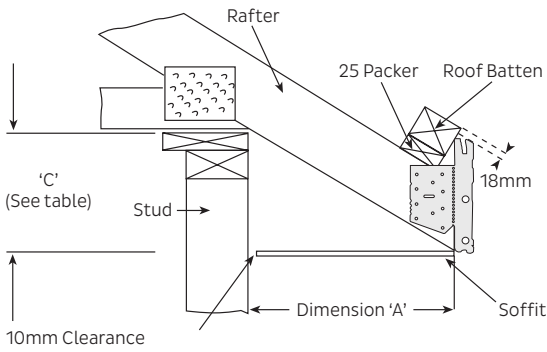

Hip & Gable Roof – Eaves Detail

Soffit Width (mm)	300	450	600
Dimension 'A' (mm)	295	445	595

Notes:

- 90x45 soffit bearer used unless stated.
- Soffit bearers fixed to right or left hand side of rafter.
- 10mm clearance allowed for soffit.

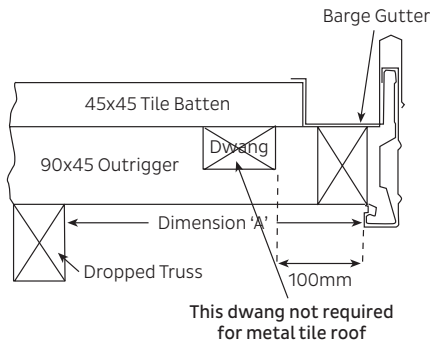

Gable End Detail

Soffit Width (mm)	300	450	600
Dimension 'A' (mm)	295	445	595

Note:

Fascia brackets must be fitted to all rafters. The installation of gutter brackets and snow straps in snow areas is to be as per section 3.1.4.7 of the Dimond manual. Snow areas N4 and N5 require 5 fasteners per Rafter bracket.

Roof Pitch (Degrees)	Drop Heights - Dimensions 'C' (mm)							
	Soffit Width (mm)							
	300		450		600		750	
	185	F180	185	F180	185	F180	185	F180
17.5	107	99	154	146	201	193	248	240
20	118	115	173	170	227	225	282	280
22.5	133	128	195	190	257	252	319	314
25	145	142	215	212	285	282	355	352
27.5	160	157	238	235	316	313	394	391
30	173	176	260	263	347	350	434	437
35	202	204	307	309	412	414	517	519
40	235	235	361	361	487	487	613	613
45	271	270	421	420	571	570	721	720

Notes for Installers

1. To ensure birds cannot enter the roof space, there should be no gap between the bottom purlin and the back face of the gutter after the system has been installed.
2. 185mm External Fascia and Gutter is not suitable on concrete tile roofs with sloping soffits.
3. NOTE: Soffit bearers are required on all hip corners and should be cut back 10 mm.
4. The use of concrete tiles on the barge ends is not a recommended practice as highlighted in the NZ Metal Roofing and Cladding Code of Practice Section 2 under Compatibility 2.7.2. Should people continue to use this method then there should be some sort of barrier between the two and there is no warranty offered by Pacific Coil Coaters or New Zealand Steel for corrosion if this method is used. This means that all installations should have a bottom batten around the edge of the roof line rather than let the concrete tile rest on the fascia.
5. Where loose fill insulation is used, the soffit must be blocked off at the top plate to prevent the insulation coming into contact with the metal fascia.
6. Zincolume® coated gutters should have a minimum fall of at least 1:500 and should not have permanent ponding. Check with your nearest distributor for further details.

MAINTENANCE REQUIREMENTS

Regular washing of all surfaces not normally washed by rainfall (called 'unwashed areas') especially around the soffit area needs to be done with clean fresh water. Regular washing may be anything from 3 monthly to 12 monthly periods. Washing should either be with a stiff soft bristled brush or water blasting at a pressure of 1500-2000 psi.

Care needs to be taken to avoid driving water into the soffit ends and roof space, by working away from soffit joints.

Should the fascia panel or parts of it become corroded over time, it must be repaired when it is first noticed. We recommend the corrosion is neutralised, then corrosion cleaned off, fascia washed down to remove dirt, oils and any grease or silicone, before priming and applying two coats of acrylic roof paint to the paint manufacturer's recommendation.

Alternatively, badly corroded lengths should be replaced, but expect colour variations due to paint fade that may not be acceptable or aesthetically pleasing for the end user.

TEST RESULTS

Regular material quality tests are carried out by our coil suppliers.

Dimond have tested 185 fascia for snow load to ensure it does not detach from the fixing brackets under a sliding 1.5 kPa snow fall on a 15° roof slope. The panel stayed attached to the fixing brackets.

165 Paltec fascia it has been used successfully in the southern lakes region and Southern South Island since the early 1990's where it has had a good history of performance where regular snow falls have occurred.

QUALITY ASSURANCE

As part of Dimond's commitment to ensuring best quality and consistent manufacture, we run consistent quality checks on the products we produce to ensure the product meets our specifications for dimension tolerances.

PRODUCT SUPPORT

Contact details for Dimond:

National Sales: 0800 DIMOND (0800 346 663)

Technical: 0800 ROOFSPEC (0800 766 377)