

## PERFORMANCE

### NATURAL LIGHTING SYSTEM PERFORMANCE STATEMENT

#### Description

Dimond Natural Lighting Systems comprise:

- Durolite®, Durolite® HeatGuard 4, Durolite® HeatGuard 8, Durolite® FireGuard 2 (FG2), Durolite® Webglass™ and Durolite® translucent fibreglass sheeting products.
- Fasteners, washers and seals
- Flashings
- Underlays and safety netting
- Additional mid span support members

#### Material Properties

Durolite® including Durolite® Webglass™ Durolite® HeatGuard 4 & Durolite® HeatGuard 8 Durolite® FireGuard 2		
Tensile Strength	80 MPa	111 MPa
Impact Strength	8 Joules	10 Joules
Shear Strength	90 MPa	90 MPa
Modulus of Elasticity	5500 MPa	5500 MPa
Compressive Strength	135 MPa	151 MPa
Flexural Strength	150 MPa	181 MPa
Specific Gravity	1.45	1.6
Water Absorption	2% in 24 hrs @ 26°C	2% in 24 hrs @ 26°C
Temperature Stability	suitability for an in-service temperature range of 20°C to 95°C	

#### Scope of Use

Dimond Natural Lighting translucent sheeting products are manufactured to the requirements of AS/NZS 4256.3:1994 in a range of profiles, sheet thicknesses and sheet compositions to meet the light transmission, wind load and durability requirements for their intended use as Natural Lighting in roofs, walls and fences of AS/NZS 4257. Specific grades of product can be manufactured to support concentrated foot traffic loads, but the standard product range is not intended to support foot traffic.

#### Requirements

In addition to the relevant content of the general Roofing and Wall Cladding System Performance Statement (Section 2.1.1.1) the Dimond Natural Lighting System design must cover the following aspects of systems performance.

- Durability 2.4.1.1.2
- Light transmission 2.4.1.1.3
- Solar heat gain 2.4.1.1.4
- Load/span capability 2.4.1.1.5
- Fastener suitability 2.4.1.1.5
- Condensation control 2.4.1.1.6
- Fire resistance 2.4.1.1.7
- Safety 2.4.1.1.8
- Maintenance requirements 2.4.1.1.2d
- Installation information 2.4.1.3
- Thermal expansion 2.1.3.4

#### New Zealand Building Code Compliance

Past history of Durolite® use in New Zealand indicates that provided the Dimond Natural Lighting Systems are designed, handled, stored, used and maintained in accordance with the guidelines given in this manual they will meet the relevant performance criteria in Clauses B1, B2, E2 and G7. In addition, fire compliance with Clause C criteria is achieved with Durolite® products, tested to verification Method C. Durolite® achieves a Group Number 3 and Durolite® FG2 achieves a Group Number 2.

**Use Outside Stated Guidelines:** If the need arises to use Dimond Natural Lighting outside the limitations and procedures given in this or other referenced literature, or if any doubt exists on product handling or use, written approval for use must be obtained from Dimond before the project commences.

## DURABILITY

### (a) Sheet Characteristics

The useful life of Natural Lighting products is determined by their ongoing ability to allow sufficient light into the building. Table 2.4A gives a guide for the recommended use of each of the product types and the expected useful life based on light transmission.

The long-term performance of Durolite® products is enhanced by the use of a 100-micron integral gel coat surface rather than a laminated polyester film.

Table 2.4A Durability Guide

	Durolite®	Durolite® HeatGuard 4 (HG4)	Durolite® HeatGuard 8 (HG8)	Durolite® FireGuard 2 (FG2)	Durolite® Webglass™	Durolite® Webglass™ Plus
<b>Performance Requirement</b>	Best for long term light transmission in industrial/commercial buildings. Achieves a Group Number 3 under NZBC C/V/M2.	Same as Durolite®. Reduces heat transmitted through sheet without large loss of light. 20% less heat without light loss compared to Durolite® Clear.	Same as Durolite®. Reduces a large amount of heat transmitted through sheet with some reduction of light. 20% less heat compared to Durolite® Opal tinted sheet.	Same as Durolite®. Achieves a Group Number 2 under NZBC C/V/M2.	Same as Durolite® but extra heavy woven glass matt allows the product to be used without safety mesh.	Same as Durolite® but extra heavy woven glass matt allows the product to be used without safety mesh. Resin uses a vinyl esta with excellent chemical resistance.
<b>Product Type and Surface Film</b>	GRP sheet with 100 micron nominal thickness, clear integral surface coating	GRP sheet with 100 micron nominal thickness, clear integral surface coating	GRP sheet with 100 micron nominal thickness, clear integral surface coating	GRP sheet with 100 micron nominal thickness, clear integral surface coating		
<b>Visible Light Transmission of New Clear Sheet</b>	63%	64%	49%	63%	-	-
<b>Total Solar Transmission</b>	63%	50%	36%	63%	-	-
<b>Expected Useful Life as Skylighting</b>	25 years	25 years	25 years	25 years	20 years	20 years
<b>Sheet Characteristics at End of Useful Life</b>						
<b>Loss of Original Light Transmission</b>	Up to 25%	Up to 25%	Up to 25%	Up to 25%	Up to 25%	-
<b>Surface Coating Condition</b>	Minimal surface degradation, gloss retained	Minimal surface degradation, glass retained	Minimal surface degradation, glass retained	Minimal surface degradation, gloss retained	Minimal surface degradation, gloss retained	Minimal surface degradation, gloss retained
<b>Glass Fibre Appearance</b>	Minimal pattern apparent	Minimal pattern apparent	Minimal pattern apparent	Minimal pattern apparent	Minimal pattern apparent	Minimal pattern apparent
<b>Sheet Yellowing</b>	Minimal	Minimal	Minimal	Minimal	Minimal	Minimal
<b>Ongoing Properties</b>	The products will remain an effective barrier to the weather for periods well in excess of their useful light transmission					
<b>Hail Resistance</b>	Sheet thickness 1.4mm or more will not fracture from 20mm ø hail impact 100km/h					
<b>Chemical Resistance</b>	Surface resistant to some hydrocarbons (e.g. toluene, petrol, mineral oils) & salt solutions.	Surface resistant to some hydrocarbons (e.g. toluene, petrol, mineral oils) & salt solutions.	Surface resistant to some hydrocarbons (e.g. toluene, petrol, mineral oils) & salt solutions.	Surface resistant to some hydrocarbons (e.g. toluene, petrol, mineral oils) & salt solutions.	Surface resistant to some hydrocarbons (e.g. toluene, petrol, mineral oils) & salt solutions.	Best surface & sheet resistance to some hydrocarbons (e.g. toluene, petrol, mineral oils) and salt solutions.

### (b) Life Cycle Costing

A comparison of installed Natural Lighting costs that includes the effect of the product durability and need for replacement is given in Chart 2.4B.

The \$/m<sup>2</sup> cost is based on market prices for the installed system discounted at 8% to compare as present value. The steps in \$/m<sup>2</sup> for each product represent the cost of removing and replacing the Natural Lighting product at the end of its useful light transmission life.

Continued on next page...

Chart 2.4B Life Cycle Cost

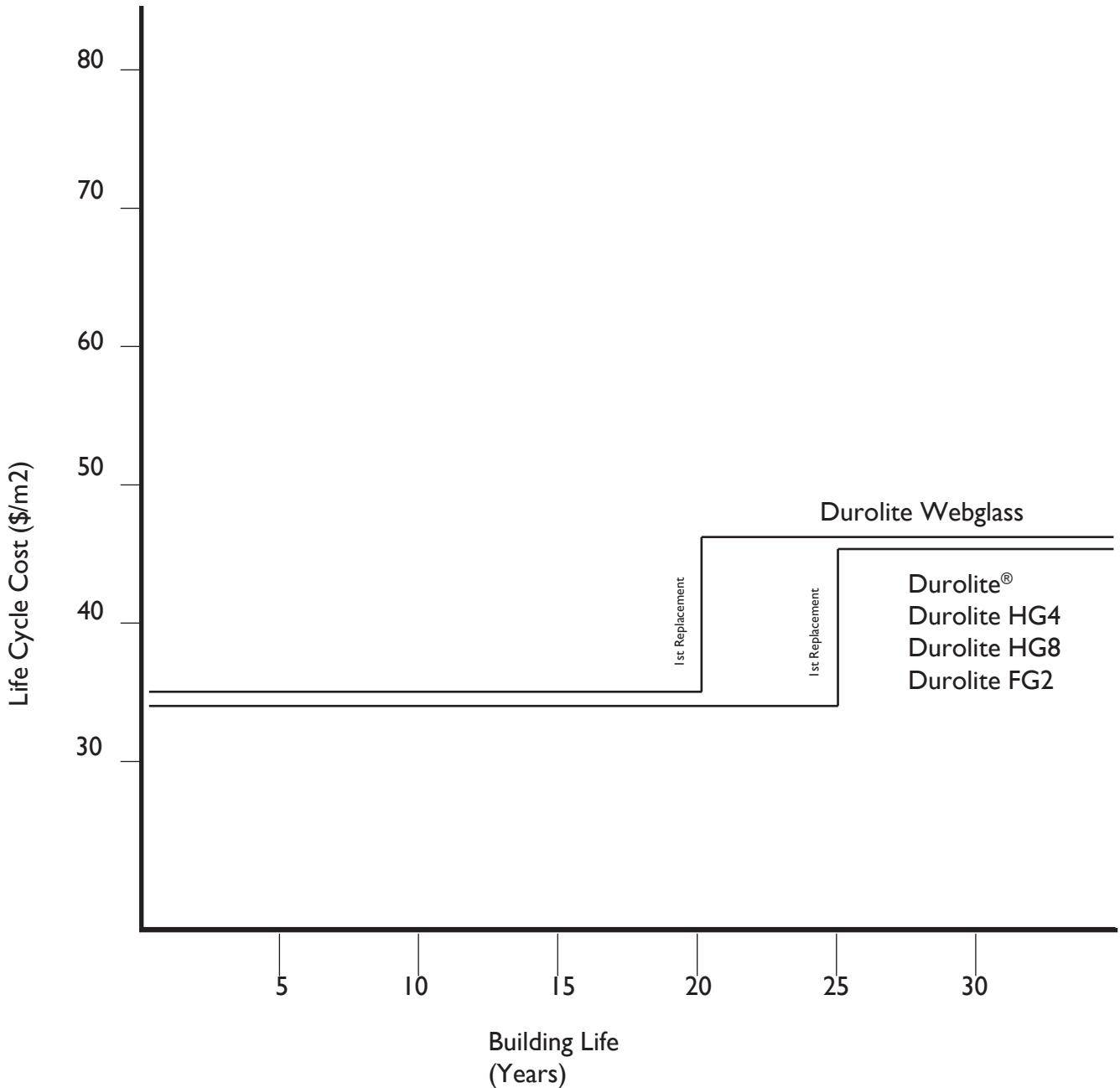

### (c) Warranty

Product performance is covered by the following warranties:

#### Durolite®, Durolite® HeatGuard 4 & Durolite® HeatGuard 8

- Will not suffer excessive yellowing and degradation to cause a light transmission loss of more than 25% from the original value when installed, for a period of 25 years from installation.
- Will not delaminate, surface erode away, allow protrusion of the reinforcing fibres through the surface, or fracture due to impact from hailstones up to 20mm diameter accompanied by winds of up to 100km/hr, for a period of 20 years from installation.
- Will not permit water to penetrate right through the sheet for a period of 25 years from date of installation.
- Durolite® will achieve a Group Number 3 in accordance with the NZBC verification method C/VM2 Appendix A.

#### Durolite® FireGuard 2

- Will not suffer excessive yellowing and degradation to cause a light transmission loss of more than 25% from the original value when installed, for a period of 25 years from installation.
- Will not delaminate, surface erode away, allow protrusion of the reinforcing fibres through the surface, or fracture due to impact from hailstones up to 20mm diameter accompanied by winds of up to 100km/hr, for a period of 20 years from installation.
- Will not permit water to penetrate right through the sheet for a period of 25 years from date of installation.
- Durolite® FG2 will achieve a Group Number 2 in accordance with the NZBC verification method C/VM2 Appendix A.

#### Durolite® Webglass

- Will not suffer excessive yellowing and degradation to cause a light transmission loss of more than 25% from the original value when installed, for a period of 20 years from installation.
- Will not delaminate, surface erode away, allow protrusion of the reinforcing fibres through the surface, or fracture due to impact from hailstones up to 20mm diameter accompanied by winds of up to 100km/hr, for a period of 20 years from installation.
- Will not permit water to penetrate right through the sheet for a period of 20 years from date of installation.
- Will remain as a trafficable sheet, resistant to foot traffic loads, for a period of 20 years from date of installation.
- Durolite® Webglass will achieve a Group Number 3 in accordance with the NZBC verification method C/VM2 Appendix A.

These guarantees are subject to conditions relating to correct storage, handling and installation, exposure to unsuitable temperatures, debris or chemicals, and to terms regarding Dimond liability.

### (d) Maintenance Requirements

Dimond Natural Lighting Systems require at least the following maintenance as a minimum to ensure the guaranteed performance is achieved. Additional regular maintenance can extend the useful life of the products.

1. Keep surfaces clean and free from continuous contact with moisture and debris. Wash at least annually using a soft bristle brush to remove dirt build-up.
2. Inspect and replace any fasteners and washers that have deteriorated sufficiently to cause leakage risk or noticeable staining.

## LIGHT TRANSMISSION DESIGN

The Durolite® range provides a source of soft, shade free natural light to building interiors. This results from the refraction by the glass fibre reinforcement in the sheet material, in contrast to the more direct and intense light and heat transmission of clear glass or clear plastic. The light transmitted excludes 99% of UVB radiation, thus minimising burning. Photosynthetically active radiation is transmitted through Durolite® allowing plant growth in greenhouse buildings.

Durolite® is available in a range of tints to reduce the level of light transmission if required. Refer Table 2.4D for Relative Light Transmission.

Opal and Woolstore tints may not be available ex stock, but can be manufactured in minimum run quantities. Discuss with your Dimond representative well in advance of your required delivery date to ensure the product required to meet your light transmission needs will be available.

### Design Method For Light Transmission

To calculate the level of light transmission through Natural Lighting installed in a building the following procedure can be used.

1. Select The Value Of External Illumination For The Location Of The Building Located From Table 2.4C.

**Table 2.4C**

Location	Latitude (Degrees South)	External Illumination (Lux)
Auckland	37	7700
Wellington	41	6450
Christchurch	43	5920
Dunedin	46	5380

EXTERNAL ILLUMINATION FOR OTHER LOCATIONS MAY BE INTERPOLATED BY LATITUDE

2. Select The Recommended Minimum Level Of Internal Illumination In Lux, Refer AS/NZS 1680.2.4
3. Calculate The Daylight Factor (A) From:  

$$A = \frac{\text{Internal Illumination} \times 100}{\text{External Illumination}}$$
4. Determine The Transmission Factor (B) For The Grade Of Natural Lighting Selected From The Range In Table 2.4D.

**Table 2.4D Relative Light Transmission**

Colour Type	Effective visible light transmission of new sheet %	Transmission factor (B)
HeatGuard 4	64	1.5
Clear	63	1.5
HeatGuard 8	49	2.0
Opal	40	2.4
Double Skin Clear or when using sky film	55 (estimated)	1.8
Woolstore	14	7.0

5. Determine Dirt Allowance Factor (C) From Table 2.4E.

**Table 2.4E Dirt Allowance Factor**

Locality	Class of Activity	Dirt Allowance Factor (C)
Country or outer suburban area	Clean	1.2
	Dirty	1.8
Built up residential area	Clean	1.4
	Dirty	2.5
Built up industrial area	Clean	1.8
	Dirty	4.0

Continued on next page...

6. Determine Reflection Allowance Factor (D) From The Table 2.4F For The Surfaces Involved Within The Building Space Using The Following Guidelines:

	Range	Typical Industrial
Ceiling	0-30%	10
Glazing	0-20%	10
Wall	0-50%	25
Floors	0-30%	15

Typical Industrial Application Average Reflection =  $\frac{10+10+25+15}{4} = 15\%$

Table 2.4F

Average Reflection	Reflection Allowance Factor (D)
15%	1.05
25%	0.96
30%	0.93
35%	0.88
40%	0.84

7. Calculate Design Factor (E) from the other factors.

$E = A \times B \times C \times D$

8. Determine The Building Dimensions Factor (F)

$F = \frac{\text{Building Length}}{\text{Wall Height} - \text{Working Plane Height}}$

9. Using E & F from above, on Chart 2.4G read off the percentage of Natural Lighting sheet required (G), for the relevant roof pitch.

Chart 2.4G

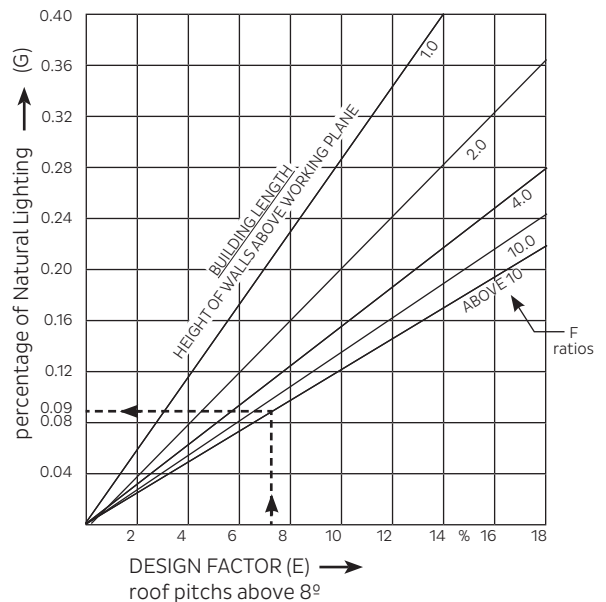
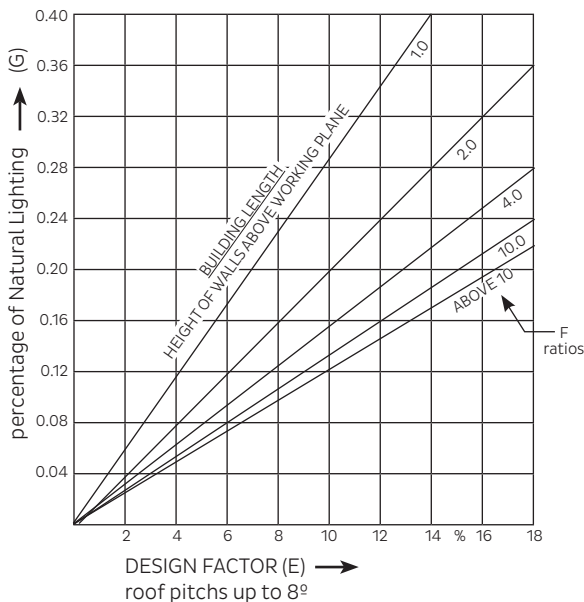

10. Calculate The Area Of Natural Lighting Required

Durolite® area =  $\frac{G \times \text{Floor Area}}{100}$

Continued on next page...

## Design Example

Calculate the amount of clear Durolite® required to give 110 lux of natural light in a building 60m x 18m x 6m walls with a 15° roof pitch in a built up industrial area of Auckland. The workbench is 1m above the floor, and the roof has a foil underlay.

From Table 2.4C External Illumination = 7700 Lux

Internal Illumination requirement of 110 lux

$$1. A = \frac{110 \times 100}{7700} = 1.4$$

2. Table 2.4D Clear Durolite® transmission factor, B = 1.5

3. Table 2.4E Dirt allowance factor, C = 4.0

$$4. \text{Average reflection calculated as: } \frac{20+10+25+15}{4} = 17.5 \text{ Table 2.4F, D} = 1.05$$

$$5. E = 1.4 \times 1.5 \times 4.0 \times 1.05 = 8.82$$

$$6. F = \frac{60}{6-1} = 12$$

From Chart 2.4G, G = 11%

$$7. \frac{11 \times 18 \times 60}{100} = 118.8\text{m}^2 \text{ of Durolite® required.}$$

## Sheet Layout

As a guide to Natural Lighting sheet layout, the designer should check that the following relationship holds,

$$\frac{\text{Distance between Natural Lighting rows}}{\text{Height of roof above working area}} < 2$$

The achievement of even dispersed light can be enhanced by using half sheet widths.

## SOLAR HEAT GAIN

There are four ways of reducing solar heat gain using the Dimond Natural Lighting range.

1. Durolite® is available in a range of clear and colour tints in Dimond profiles to reduce the level of solar heat gain as required. Refer to Table 2.4I for relative solar heat gain.
2. Use Durolite® HeatGuard 4 (HG4) in any of the Dimond profiles to reduce the total solar transmission by 13% without any noticeable loss of visible light transmission when compared to Durolite® clear (which allows 64% of visible light through the sheet).
3. Use Durolite® HeatGuard 8 (HG8) in any of the Dimond profiles to further reduce the total solar transmission. When compared to tinted Durolite® opal sheet, Durolite® HG8 has similar solar heat gain characteristics, while still allowing 49% of visible light through the sheet.

For the System in point 1 above, the heat gain resulting from the use of Durolite® can be estimated in a simple way using the following calculations: (This does not take into account heat transmissions through other materials making up the building envelope.)

### Design Method for Solar Heat Gain

Total instantaneous heat gain =  $Q_i + Q_c$  (watts)

Where  $Q_i$  = instantaneous solar gain

$Q_c$  = conduction heat gain/loss through Natural Lighting sheeting

To calculate instantaneous solar gain ( $Q_i$ ) use:

$$Q_i = A \times \text{SHGC} \times E$$

A = Area of Natural Lighting sheeting (m<sup>2</sup>)

SHGC = Solar heat gain coefficient. Refer Table 2.4I

E = Solar Irradiance (W/m<sup>2</sup>) Refer Table 2.4H

Table 2.4H

Zone	Solar Irradiance E (Average) (W/m <sup>2</sup> )
Auckland	752
Wellington	733
Christchurch	695
Dunedin	592

Table 2.4I Relative Solar Heat Gain

Colour/Type	SHGC	Total Solar Transmission
Clear	0.73	63%
Opal	0.42	36%
Woolstore	0.19	16%
HeatGuard 4	0.58	50%
HeatGuard 8	0.41	36%

To calculate conduction heat gain/heat loss ( $Q_c$ ) use:

$$Q_c = A \times U \times T_d$$

A = Area of Natural Lighting sheeting (m<sup>2</sup>)

U = Thermal transmittance W/m<sup>2</sup> °C from Table 2.4J

E = Solar Irradiance (W/m<sup>2</sup>) Refer Table 2.4H

Table 2.4J Thermal Transmittance U (W/m<sup>2</sup> °C)

	Single Skin	Double Skin Air Gap		
		100mm	50mm	DSR 5
Heat flow down (Heat Gain)	2.2	0.9	1.0	1.1
Heat flow up (Heat Loss)	-4.8	-1.9	-2.0	-2.2

This table includes internal and external boundary layer effects.

For example: To calculate the total heat gain of an Auckland building with 43.2m<sup>2</sup> of Clear Durolite® single skin roofing with a temperature difference of 8°C (warmer inside than outside).

Solar Heat Gain  $Q_i = A \times \text{SHGC} \times E$   
 $= 43.2 \times 0.73 \times 752$   
 $= 23.7\text{kW}$

Conductive Heat Gain  $Q_c = A \times U \times T_d$   
 $= 43.2 \times (-4.8) \times 8$   
 $= -1.66\text{kW}$

Total Instantaneous Heat Gain  $Q = Q_i + Q_c$   
 $= 23.7 - 1.66$   
 $= 22.04\text{kW}$



## LOAD SPAN DESIGN

Table 2.4K provides the maximum spans for each Durolite® product type in all the grades such as clear, HG and FG for each profile and sheet thickness limited by the ultimate limit state capacities given. The load span data is based on the number of fasteners/sheet/purlin given. The load capacities apply to both inward and outward uniformly distributed loads. Table 2.4K does not cover Natural Lighting Systems intended to support concentrated loads (e.g. foot traffic). Consult Dimond for alternative systems if design consideration is to be given to concentrated load support.

### Fastener Design

Dimond Natural Lighting sheets must be fixed with screw fasteners of the same type and length for the matching metal sheeting. The fastener frequency should be specified according to Table 2.4K.

Weatherlok roofing washers may be used to achieve a seal and to spread wind uplift reaction loads. For roofs with design wind loads close to the maximum values below or above 2.0 kPa, use the matching metal profiled washer and 36Ø EPDM seal. Side lap stitching and pre-drilled oversize holes may be required (refer Section 2.4.1.3.2).

**Table 2.4K Natural Lighting Systems – Load / Span / Fastener Design**

Profile	Gauge (mm)	Nominal Sheet Weight/m <sup>2</sup> Kg/m <sup>2</sup>	Maximum Internal Span (mm) End Span = 0.7 x Internal Span			Fasteners per sheet per purlin	
			U.L.S <sup>5</sup> 1.0 kPa	U.L.S <sup>5</sup> 1.5 kPa	U.L.S <sup>5</sup> 2.0 kPa	End Span	Internal Span
Corrugate Min pitch 8°	1.1	1.8	1200	1000	900	5	3
	1.4	2.4	1400	1200	1000	5	3
	1.7	3.0	1500	1300	1200	5	3
Veedek®/Styleline/ Hi Five Min pitch 3°	1.1	1.8	1400	1200	1000	4	4
	1.4	2.4	1700	1500	1200	4	4
	1.7	3.0	1900	1700	1400	4	4
V-Rib Min pitch 4°	1.1	1.8	1400	1200	1000	5	3
	1.4	2.4	1700	1500	1200	5	3
	1.7	3.0	1900	1700	1400	5	3
LT7® Min pitch 3°	1.1	1.8	1600	1400	1300	7	4
	1.4	2.4	1900	1700	1500	7	4
	1.7	3.0	2100	1800	1700	7	4
BB900 Min pitch 3°	1.1	1.8	1700	1400	1300	6	3
	1.4	2.4	2000	1700	1500	6	3
	1.7	3.0	2300	1900	1700	6	3
DP955® Min pitch 3°	1.1	1.8	1400	1000	750	3	3
	1.4	2.4	1900	1300	900	3	3
	1.7	3.0	2500	1600	1200	3	3
SS900/Topspan® Min pitch 3°	1.1	1.8	1800	1600	1400	4	4
	1.4	2.4	2000	1800	1400	4	4
	1.7	3.0	2300	2000	1700	4	4
Super Six Min pitch 3°	1.1	1.8	1800	1400	1200	4	4
	1.4	2.4	2000	1600	1400	4	4
	1.7	3.0	2300	1800	1600	4	4
Dimondek® 400 Min pitch 3°	0.75	1.9	1400	1200	1000	1 Clip	1 Clip
	0.9	2.3	1600	1400	1200	1 Clip	1 Clip
Dimondek® 630 Min pitch 3°	1.4	2.4	2200	1500	1100	3	3
	1.7	3.0	2800	1900	1400	3	3
	2.2	3.6	3500	2500	1900	3	3
Six Rib Min pitch 4°	1.1	1.8	1200	1000	900	6	6
	1.4	2.4	1400	1200	1000	6	6
	1.7	3.0	1500	1300	1200	6	6

**Note:**

1. The spans given are for internal purlin spacings.
2. The tabulated data does not apply to single spans. Single spans must be reduced to 0.5 x internal span.
3. These spans apply where the Natural Lighting sheets are installed with both side edges supported by an adjacent metal roof.
4. For continuous coverage of two or more Natural Lighting sheets we recommend reducing the spans 0.9 x Internal spans.
5. U.L.S. = Ultimate Limit State Capacity.

## Mid Span Support

Whenever the span capability of the Dimond Natural Lighting product does not match the purlin spacing used for the adjoining metal sheets, a mid span support must be used. The sheets must be fastened to the mid span support in the same manner as they are fastened to the purlins. Mid span supports are required to reduce sheet flutter due to wind loads and are not intended to support concentrated loads.

## ½ Sheet Widths Spans

The use of profiled ½ sheet widths, lapping over the side of the steel sheets, allow the spans of the selected profile Natural Lighting sheet to be increased by up to 40%, while still achieving the same ultimate limit state capacity, before needing mid supports. Half width sheets must have side lap stitching as shown in Table 2.4M, Section 2.4.1.3.2.

## CONDENSATION CONTROL & INSULATION

Condensation can occur on the underside of Natural Lighting sheet when the building is not sufficiently ventilated or moisture is generated within the building space.

The following three methods are recommended options to help reduce the effect of condensation that may form on Natural Lighting.

1. Install a system that incorporates Dimond Skylight film as a translucent underlay. Refer 2.4.1.1.10 Detailed Drawings Fig. 1. This is a low performance system which in the extreme cases of low exterior temperatures, condensation may still form on the underside of the skylight film. Otherwise the skylight film is intended to carry condensation moisture dripping from the underside of the Natural Lighting sheet to the outside of the building, similar to building paper.
2. Install a system that incorporates a double skin of Natural Lighting sheeting with an air gap between. In colder climates the air gap provides additional insulation and reduces the likelihood of condensation forming on the underside of the inner surface.

For additional design considerations relating to condensation control by ventilation, refer to Section 2.4.4.

## FIRE RESISTANCE

The fire resistance properties of the Natural Lighting products have been evaluated by recognised Fire Safety Consultants, resulting in the opinion that Durolite® can be used within the New Zealand Building Code requirements for fire safety given the following guidelines.

Durolite® and Durolite® FireGuard 2 (FG2) are manufactured with fire retardant polyester resin and have been tested by BRANZ.

Durolite® achieves a Group Number 3 classification to the NZBC verification method C/VM2 Appendix A. Durolite® uses a bromine free formulation.

Durolite® FG2 achieves a Group Number 2 classification to the NZBC verification method C/VM2 appendix A.

BRANZ Test Reports for Durolite® Group Number classifications are available upon request. Contact Dimond on 0800 ROOFSPEC (0800 766 377).

Durolite® and Durolite® FG2 is available in all profiles and standard colour tint options, e.g. HG4.

## SAFETY

Impact tests carried out to AS/NZS 4040-4:1996 on Dimond Natural Lighting sheets supported by metal roofing sheets on either side, have shown that sufficient impact resistance to meet safety requirements without the installation of safety mesh can be achieved if the Natural Lighting sheet thickness is at least 1.7 mm.

The maximum span for each profile to pass the safety impact test is given in Table 2.4L.

**Table 2.4L**

Profile	Sheet Thickness (MM)	Maximum Span (mm) to meet Impact Safety
Corrugate	1.7	1500
Styleline / Veedek®/Hi Five	1.7	1800
V-Rib	1.7	1800
LT7®	1.7	2000
BB900 & DP955®	1.7	2200
SS900 / Topspan®	1.7	2400
Super Six	1.7	1800
Six Rib	1.7	1800

The Dimond Natural Lighting sheets with safety mesh laid under are not intended to carry foot traffic and Dimond recommend using Dimond Webglass if trafficable sheets are required.

When accidental fall safety is an issue, usage outside the scope of this table (e.g. different profiles, thinner sheet or greater spans) may require the installation of an approved safety mesh – see Section 2.4.5.

Alternatively Dimond Webglass may be used, which is manufactured to a thicker sheet weight of 2.1 mm and reinforced with a heavy woven glass mat which provides continuous reinforcement both across and up the profiled sheet. This reinforcement gives the sheet enough strength under an impact load such that safety mesh is not required under the webglass sheet.

## DETAIL DRAWINGS

Fig 1 Dimond Skylight Film Detail

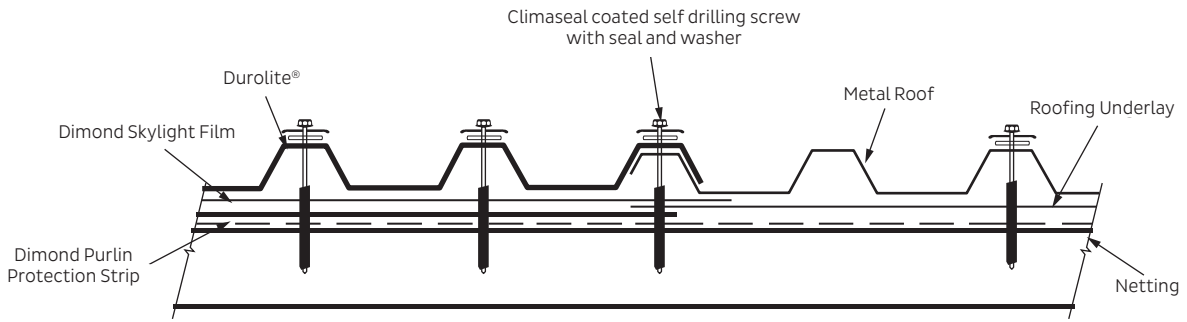

FIG 2 has been deleted

Fig 3 Detail At Ridge

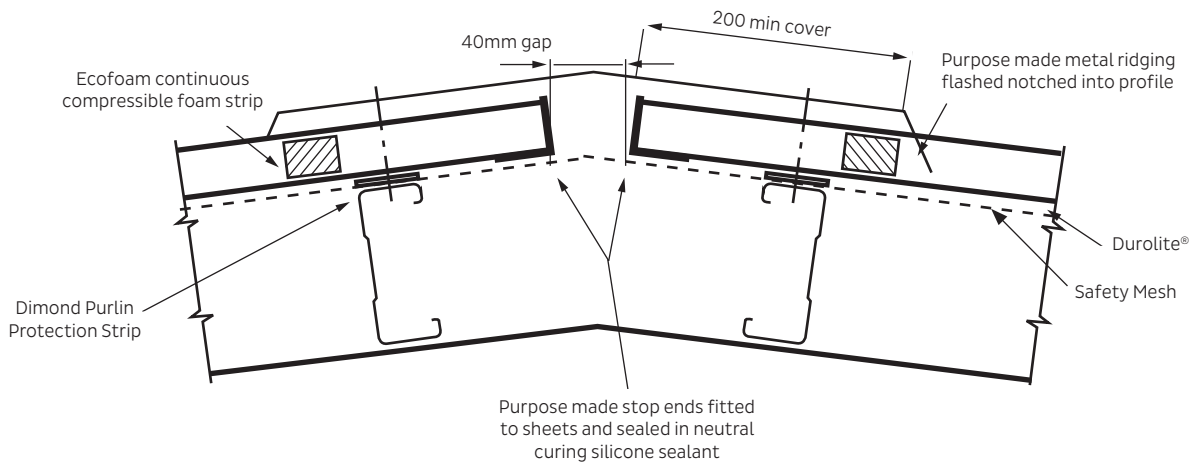

Fig 4 End Lap Duro-lite® to Duro-lite® & Duro-lite® to Steel

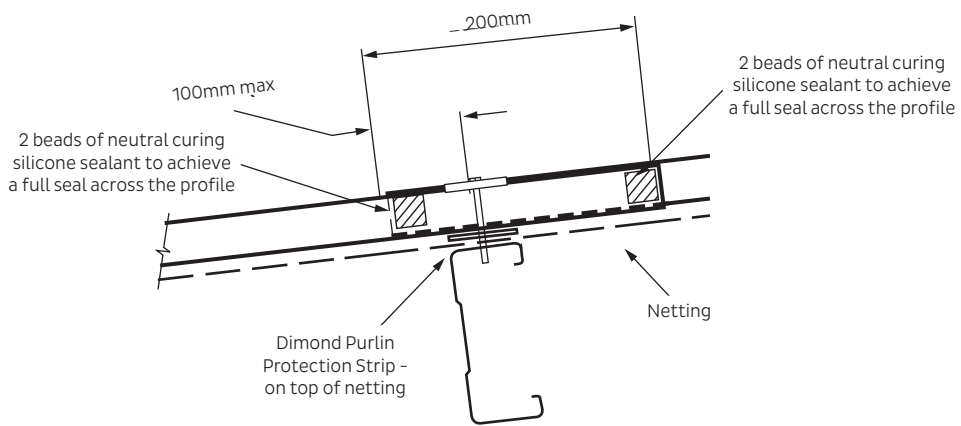

Fig 5 Stop End Detail

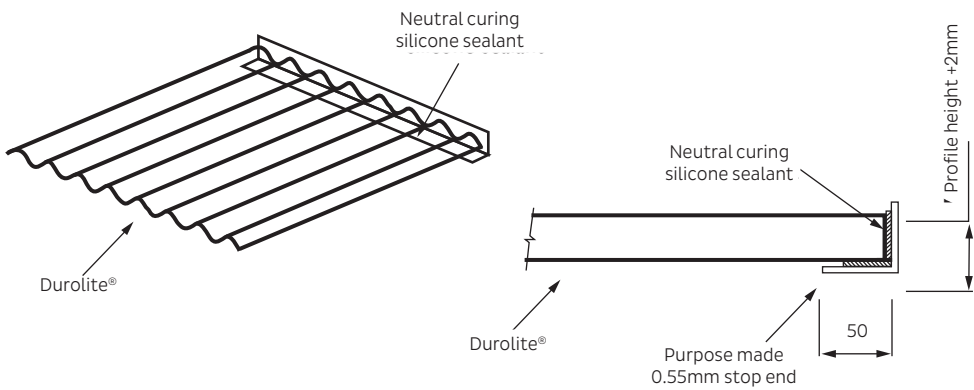

Fig 6 Side Lap Detail of Durolite® With Metal Roofing (Over/Over Process)

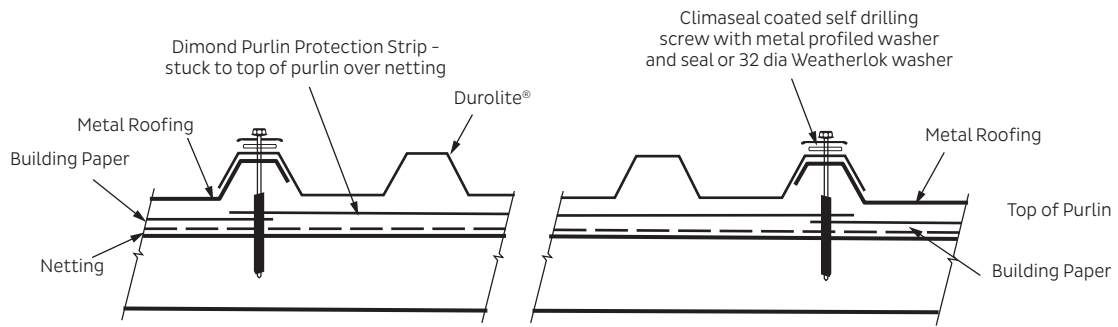

Fig 8 Detail For Single Durolite® Sheet With Dimondek® 300 or Dimondek® 400

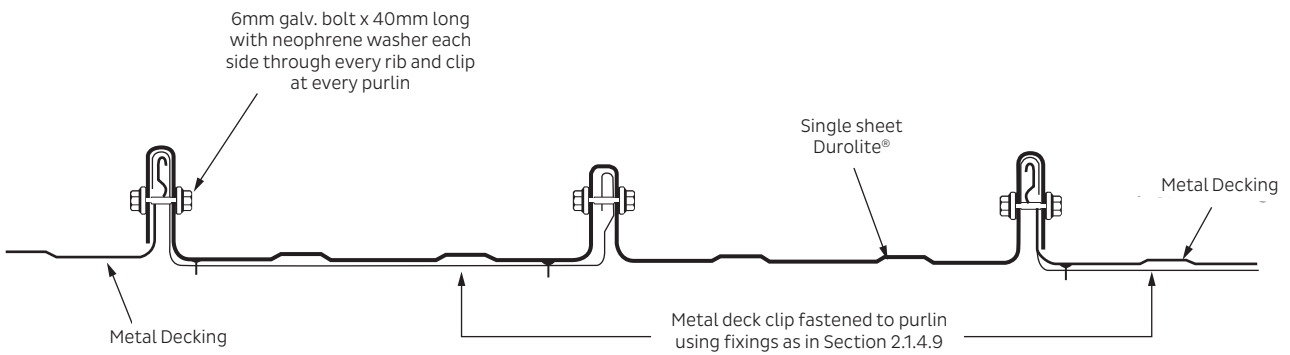
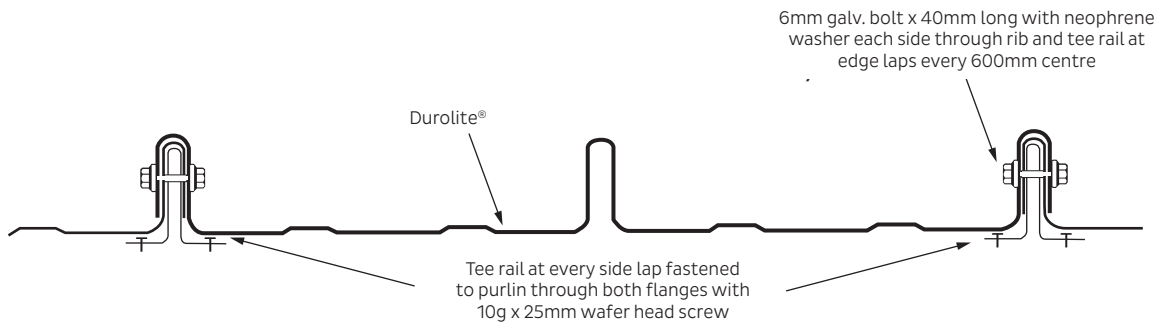

Fig 9 Multiple Durolite® Sheet Detail With Dimondek® 300 or Dimondek® 400



Continued on next page...

Fig 10 Durolite® Dimondek® 630 Side Lap Detail With Metal Roofing (Over/Over Process)

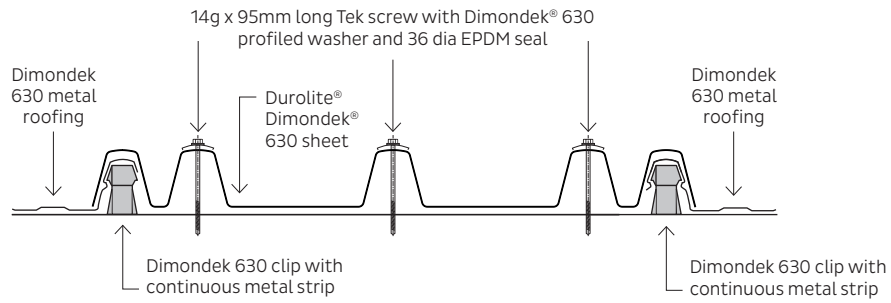

Fig 11 DSR5 Skylight Detail

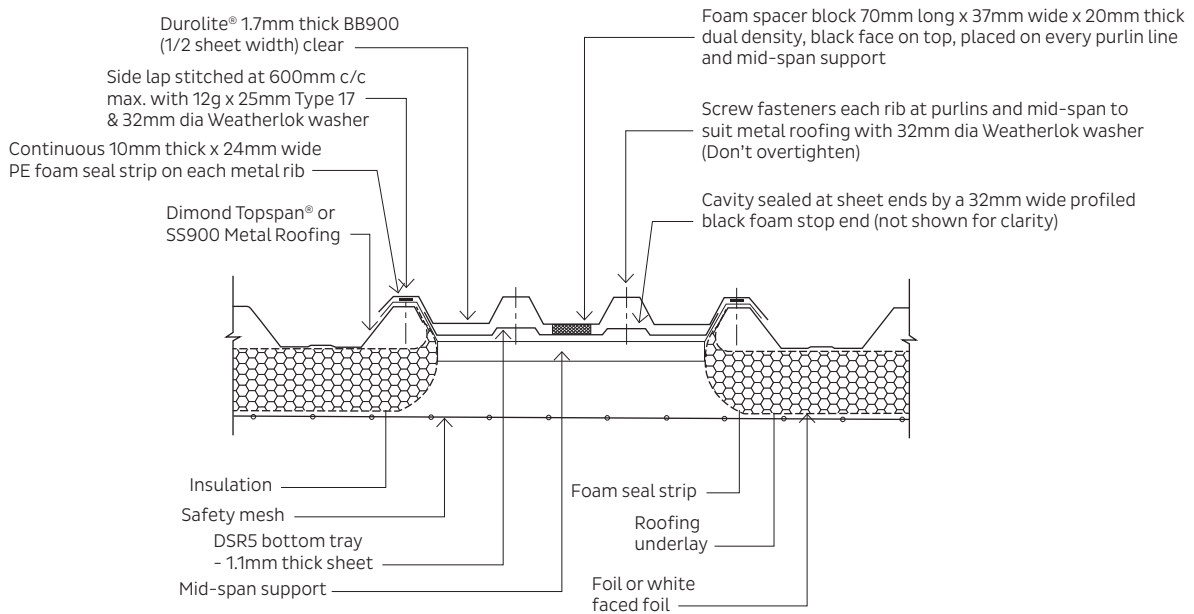
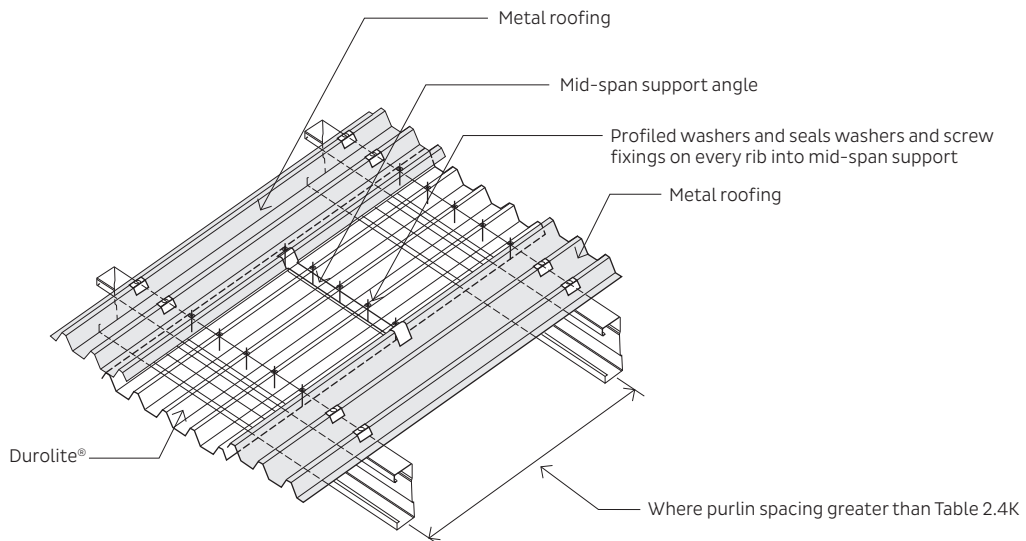
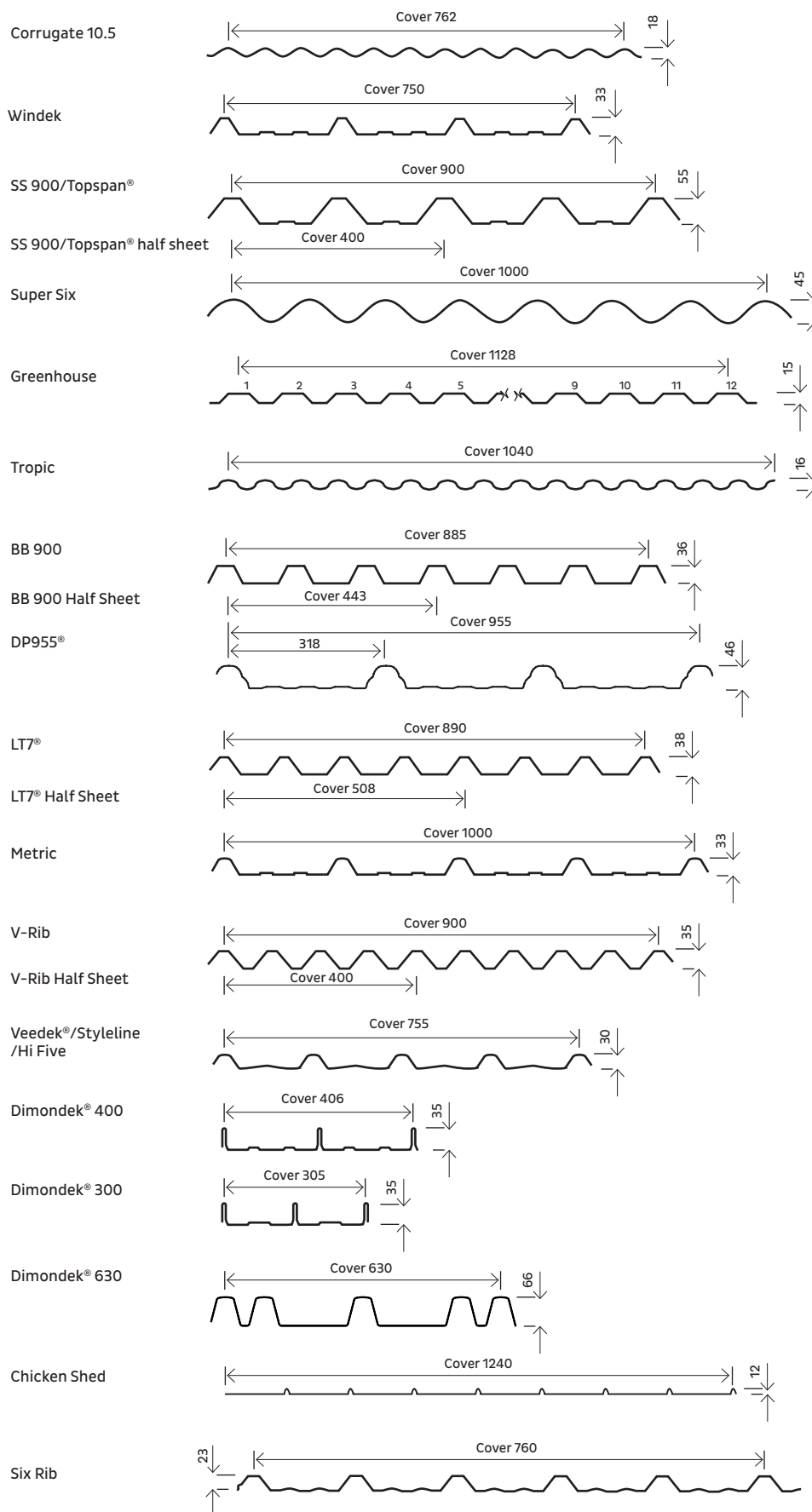

Fig 12 Mid-Span Support Detail (All Profiles Except Decking)



## COMPONENTS - PROFILE RANGE

The following profiles are available in all Dimond Natural Lighting products. In addition, profiles matching most other metal roofing products may be available.





## DIMOND PURLIN PROTECTION STRIP

The recommended strip to use as a barrier between the purlin/mesh and Natural Lighting sheets is Purlin Protection Strip (PPS). These flat sheet strips of GPP are provided with double sided tape on one side for attachment onto the purlin over the netting or safety mesh before the Natural Lighting sheets are fixed down. They are supplied in either 70mm or 90mm wide strips to best suit the purlin flange width.

## FASTENERS

1. Primary Natural Lighting sheet fasteners should be the correct length gauge and grade of screw fastener for the profile and will therefore be specified as the same fastener as for the adjoining metal sheeting. Clearfix 12g x 65mm long hex head self-drilling screws, drill both an oversized clearance hole in the Natural Lighting sheet and self drill into timber or steel purlins. Suitable for Corrugate, Styleline/Veedek®/Hi Five/Six Rib, Dimondclad into timber or steel purlins and DP955®, BB900, LT7® and V-Rib profiles into steel purlins only.
2. Washers, metal profiled shaped washers used with a 36Ø EPDM seal.
3. Lap stitching fasteners
  - Stitching to metal – 2.2.3.1
  - Stitching to fibreglass sheet – gutter bolt with compressible rubber sleeve

## DIMOND SKYLIGHT FILM

Manufactured by Agpack Plastics Limited specially for use as a low cost condensation carrier/barrier beneath Dimond Natural Lighting products. The film is manufactured from a mix of virgin polymers to give a high tear resistance, and has additives for protection against rapid UV degradation. The film carries a durability period of 10 years. Genuine Dimond Skylight Film is branded on the film and has a thickness of 125 microns. Available in widths of 1000mm or 1300mm and roll sizes of 50 Lm or 100 Lm.

## FLASHINGS

Metal flashings – see Section 2.1.3.6.

Natural Lighting Stop End – purpose made angle to suit profile rib height and to extend at least 50mm under the sheet to allow fixing and silicone sealant.

## MID SPAN SUPPORT

Purpose made angle with folded end profiles to fit over adjoining metal sheeting ribs. For Dimondek® 630 the end profiles fit under and snap into the rib. Manufactured from 0.95mm G250 Z450 galvanised steel unless otherwise specified. The mid span support is not intended to support point loads from foot traffic.

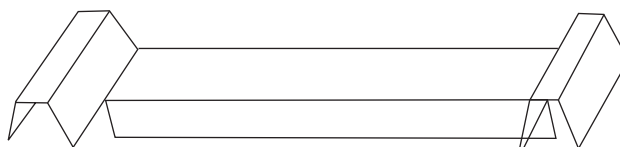

## SAFETY MESH

Ausmesh – see Section 2.4.5.

## PROFILE STRIP

Closed cell foam strip to match sheet profile see Section 2.2.4.2.

## INSTALLATION INFORMATION

### HANDLING AND STORAGE

Dimond Natural Lighting sheets are delivered to the site in bundles which should remain strapped together and stored where damage will not occur. Ensure the product remains clean and dry. Edges of bundles must be protected during craning. Sheets must be lifted into place, not dragged.

Durolite® has a 100 micron integral gel coat top surface which is less likely to suffer damage during handling that will affect long term performance. The underside however does have a thin plastic film laminate and care must be taken to avoid damaging it.

### SHEET LAYOUT AND FASTENERS

#### (a) Supporting Structure

Before installation is commenced, the supporting structure must be free of sharp protrusions, or abrasive surfaces that may come into contact with the sheets. Ensure the purlin spacing is not greater than the span limitations for the selected profile as detailed in Section 2.4.1.5. A pliable, non-abrasive separation layer must be placed between the sheet underside and the wire netting/purlin surface. Refer to Section 2.4.1.2.2.

#### (b) Mid Span Support

In instances where single Dimond Natural Lighting sheets are to be used as skylights and placed between adjacent metal sheets, they may be installed on purlin spacings that exceeds the maximum span limitation for the sheet thickness chosen provided a mid span support member is incorporated to enable extra fastening to reduce sheet flutter in high winds. See Fig 12 for typically installed view. Where two or more Dimond Natural Lighting sheets are laid side by side purlin spacings must be reduced to suit the maximum span of the Natural Lighting material. (For decking profile refer to paragraph (e) below.)

#### (c) Layout

Sidelaps are designed for both edges of the Natural Lighting sheets to overlap the adjoining metal sheets. All sidelaps must lap over the profile rib of the sheet. It is preferred that the sheets are run from ridges to eaves without end laps. Where end laps are necessary, they should be a minimum of 200mm and fully sealed at both edges of the lap with a neutral cure silicone sealant. Laps must be positioned on a purlin in such a manner that the overlapping sheet edge is firmly fastened against the underlapping sheet.

#### (d) Fastening

Dimond Natural Lighting sheets will undergo movement at the fastener position. To correctly allow for this, the sheets should be pre-drilled through the crest of the rib or corrugation with a hole diameter at least 2mm greater than the screw. Larger pre-drilled holes will be required if the sheet length is greater than 6m and allowance for thermal expansion is required – see Section 2.1.3.4.

Ensure the correct fixings and washers are used in accordance with Section 2.4.1.1.5.

Screw fasteners must be tightened sufficiently to prevent the sheet lifting from the framing but not overtight so as to cause rib deformation. To control sheet flutter in high winds side lap stitching through the rib top is required similar to the primary fasteners and should be completed at spacings that achieve the side lap fastening required in Table 2.4M. Use profiled washers with 36Ø EPDM seals into 12mmØ oversized holes in the natural lighting sheets.

Table 2.4M

Profile Rib Height	Max. Side Lap Fixing Centres (mm)
30mm or less	450
Greater than 30mm	600
Dimondek® 630	900

Continued on next page...

### (e) DD400 Decking Profile

Where one sheet of Natural Lighting DD400 or decking profile is used in conjunction with the metal decking, the sheets are laid using the under/over method. The sheets are held in position by galvanised bolts, which are located through each rib. The bolts must also pass through the rib of the metal decking and the deck clip to ensure correct hold down is achieved. If purlin spacings are greater than 1200mm centres or in high wind areas additional bolts must be placed through the sheet edge laps at 600mm centres. Where two or more Natural Lighting sheets are laid side by side, deck clips are replaced by Dimond Tee Rails manufactured from .55mm G550 Z450 Galvanised Steel or AZ150 Zinalume.® These are located at every side lap. Fixings are placed through ribs and Tee Rails at 600mm centres ensuring that a fastener is immediately adjacent to the purlin. The Tee Rail must be fixed to the purlin through both flanges.

### (f) Dimondek® 630 Profile

It is intended to fix one natural lighting sheet between adjacent steel Dimondek® 630 sheets for sheet support.

Multiple natural lighting sheets can not be side lapped and fixed down as adjacent sheets as the profile rib shape does not allow this. We recommend laying a steel sheet then natural lighting sheet, then another steel sheet and so on, if this effect is required.

Span breakers are used to reduce the purlin spacing of the natural lighting sheets only and are installed from the top side of the roof. They can only be installed one way around with the larger rib on the span breaker clipping and snapping up into the underside of the steel overlap rib.

The middle rib clip fixing post must be removed before the Durolite sheet is placed in position.

The outer side ribs of the natural lighting must not be fixed down. They fit over the steel sheet ribs allowing differential movement between Durolite and steel Dimondek® 630 sheets.

Self drilling fixings are used on the inner three ribs only. A 10mm diameter clearance hole must be drilled through each of the inner three ribs and 14g x 95mm Tekes with a Dimondek® 630 profiled washer and 36mm diameter EPDM seal are then screwed into each clearance hole on every purlin and/or span breaker.

Where end lapping of sheets to form runs of over 25m is required, we recommend overlapping 200mm, applying 4 beads of neutral curing silicone sealant approx. 10mm diameter in size. Allow these to tack off for 20 minutes before screwing down. This will allow the beads of silicone to roll and not shear under thermal expansion, and continue to provide a seal.

Refer 2.4.1.1.10, Fig. 10 for further detail.

## FLASHINGS AND STOP ENDS

In addition to normal requirements (refer Sections 2.2.4 and 2.3.3) stop ends must be provided on all roof pitches, at the top end of all Natural Lighting sheet installations to provide a watertight seal under all over flashings, including immediately below any roof penetration. Sheet stop ends can be achieved by using either:

- Compressible Closed-Cell Foam Strip to match the profiles. Use if roof pitch is greater than 15 degrees.
- Metal angle folded to the height of the profile rib and fastened to the end of the sheet with rivets. Neutral curing sealant is then applied to the intersection of the sheet and metal angle. Refer Section 2.4.1.1.10, Fig. 5.

## GENERAL WORKMANSHIP

In addition to normal requirements (refer Section 2.3.4) note the following:

### 1. Sheeting Cutting

Natural Lighting sheets can be supplied cut to custom lengths. Where onsite cutting is necessary a fine tooth handsaw or an electric saw fitted with a fibre disc must be used. Breathing protection must be worn to prevent inhalation of glass fibres and resin dust. To resist cracking, the sheets must be firmly supported during cutting operations.

### 2. Water Run-Off

Dimond Natural Lighting sheets, as with any other plastic or prepainted metal roofing materials, act as inert catchment areas for rainwater, and run-off from these areas onto unpainted galvanised surfaces may cause accelerated corrosion of the galvanised steel.

## PERFORMANCE

### CURVED ROOFING PERFORMANCE STATEMENT

The performance of Dimond Curved Roofing Systems is covered by the statement for straight roofs together with the additional criteria set out below.

Curved roofing systems are available in three basic forms:

1. Crimp Curved	Reference
Available in a restricted range of metal profiles and to a minimum machine crimped radius limitation.	2.4.2.1.2
Single curves, or combinations of straight, convex and concave are available, but with some restrictions that must be discussed with Dimond at the design stage of each project.	2.4.2.1.2
Attention at the design and installation stages must be given to correct sheet layout, end laps, and water catchment for low pitch areas.	2.4.2.1.2
Extra maintenance washing of crimp curved sheets may be required to remove dirt build-up at the crimps or in areas not naturally washed by rainfall.	
Transport and handling will limit sheet lengths and shapes and must be discussed with Dimond at the design stage of each project.	
2. Drape Curved	
Recommended for a restricted range of profiles in metal, Duraclad® and Natural Lighting materials.	2.4.2.1.3
Minimum curve radius is limited by the appearance of the roof sheet.	2.4.2.1.3
Roof purlin design must take into account the purlin deflection and reaction that will result from the load to hold drape curved sheet in place. As a guide this load can reach 2.5 kN/m or more on the purlin depending on radius and material.	
Water catchment for low pitch areas must be considered in relation to the sheet side laps, and may limit the maximum curve radius.	2.4.2.1.3
3. Roll Curved	
Available in a restricted range of metal profiles and to a minimum machine rolled radius for each profile and material.	2.4.2.1.2
Single curves, or a combination of straight, convex and concave are available but with some restrictions that must be discussed with Dimond at the design stage of each project.	2.4.2.1.2
Attention at the design and installation stages must be given to correct sheet layout, end laps, and water catchment for low pitch areas.	2.4.2.1.2
Transport and handling may limit sheet lengths and shapes, and must be discussed with Dimond at the design stage of each project.	

In all three curved roof systems penetrations, sheet termination (e.g. abutting walls, apex) and end lapping must be avoided in areas of the roof where the pitch is less than the minimum required for the profile.

## CRIMP CURVED AND ROLL CURVED ROOFING SYSTEM DESIGN

Combinations of curves and straight sections must be laid out on the roof to fit purlin locations where fastening and sheet end laps occur. Basic rules that govern the design are:

1. Straight tails on curves must span across at least two purlins.
2. Maximum length from curve to tail end is normally limited by transport and handling to 6m.
3. Laps must be in areas of roof pitch that meet the minimum pitch requirement for the profile.
4. A roof shape transition from convex to concave curves must have a straight section of at least 300mm located over a purlin to allow fixing.

**Table 2.4M**

Profiles and material available for crimp curved systems are

Profile	Material and BMT (mm)		Minimum Radius (mm)
LT7®*	Steel G550	0.40	400
	Steel G300	0.55	400
	Aluminium H34	0.90	400
V-Rib	Steel G550	0.40	400
	Steel G300	0.55	400
Styleline*/Hi Five	Steel G550	0.40	400
	Steel G300	0.55	400
	Aluminium H34	0.90	400

Profiles and materials available for roll curved systems are

Profile	Material and BMT (mm)		Minimum Radius (mm)
Corrugate	Steel G300	0.40	450
	Steel G300	0.55	450
	Aluminium H36	0.70	1200
	Aluminium H36	0.90	450

\*Note that 0.40mm LT7® and Styleline are not recommended for crimp curing to a radius greater than 900mm (refer Section 2.4.2.2.1)

## DRAPE CURVED ROOFING SYSTEM DESIGN

### Recommended Curve Radius

#### Minimum Radius

The minimum curve radius for each profile is restricted by the appearance of the roof sheet. As the radius is reduced the “pan” of the profile will begin to exhibit compression ripples that will detract from a clean appearance, and eventually reach a level that is generally regarded as unacceptable.

The minimum radius given below for each profile, together with the purlin spacing recommended for use at the minimum radius, will ensure the clean appearance of the drape curved roof with minimal ripple effect.

Specific aesthetic requirements for drape curved roofing must be discussed with Dimond at the design stage.

#### Maximum Radius

The maximum curve radius for each profile is restricted by the need to have the selected profile roof-sheeting reach its minimum recommended pitch at the gutter line for the profile used.

This restriction ensures large radius “flat” roofs are not used.

In addition, the maximum radius limitation and profiles given below for Corrugate profile ensures that water catchment on the low pitch area of the curve will not overflow the profile valleys due to inadequate run-off.

**Table 2.4N Drape Curved System – Recommended Profiles and Radius Limitations**

Recommended Profile	Recommended Radius							Maximum (m)
	Minimum (m)							
	G550 Steel		H36 5052 Aluminium		Natural Lighting		Duraclad®	
	0.40mm	0.55mm	0.70mm	0.90mm	1.1mm	1.4mm	1.7mm	
Corrugate	12	10	12	10	4	5	8	Note 1
V-Rib	20	16	20	16	12	14	20	Note 2
Styleline/Hi Five	80	40	80	40	8	9	12	Note 2
LT7®	80	50	80	50	12	14	24	Note 2
Dimondek® 400	N/A	70	N/A	70	16	18	N/R	Note 2
BB900	N/R	90	N/R	90	12	14	24	Note 2
DP955®	N/R	70	N/A	N/A	70	70	70	Note 2
Steelspan 900	N/A	120	N/R	120	16	18	30	Note 2
Topspan®	N/R	120	N/R	120	16	18	30	Note 2
Baby Corrugate	2	2	2	2	N/A	N/A	N/A	Note 4
Dimondek® 630	N/A	250 (Note 5)	(Note 6)	(Note 6)	250 (Note 7)	250 (Note 7)	N/A	Note 2
Super Six	N/A	N/A	N/A	N/A	16	18	30	Note 2
Six Rib	30	22	22	N/A	5	6	6	Note 2
Solar-Rib®	N/A	90	N/A	90	N/A	N/A	N/A	N/R
Heritage Tray®	N/A	N/A	N/A	N/A	N/A	N/A	N/A	N/R
Eurotray® Lite	N/A	N/A	N/A	N/A	N/A	N/A	N/A	N/R
Eurotray® Double Standing Seam	N/A	**2.5	0.6	N/A	N/A	N/A	N/A	N/R
Eurotray® Angle Seam	N/A	**2.5	0.6	N/A	N/A	N/A	N/A	N/R
Eurotray® Roll Cap	N/A	N/A	N/A	N/A	N/A	N/A	N/A	N/R
Eurotray® Roll Seam	N/A	**2.5	0.6	N/A	N/A	N/A	N/A	N/R

\*\*G300 Steel Only

**Note 1:** Maximum radius for Corrugate is determined by the maximum run of roof that is below the minimum pitch, measured from the apex, shall not exceed 5m. Maximum radius may be further restricted by the criteria in Note 2.

**Note 2:** Maximum radius determined by the need for the roof pitch to reach the minimum requirement for the profile at the gutter line. Maximum radius will therefore depend on the building width.

**Note 3:** For the recommended maximum purlin spacing, the unrestricted access roof purlin spacing should be used to achieve a smooth curve (ref section 2.1.4 for the selected profile).

**Note 4:** The Baby Corrugate profile is not recommended for use as a roof product. It is only intended as cladding.

**Note 5:** DD630 is also available in 0.48mm thick steel and will achieve the same radius as 0.55mm steel.

**Note 6:** For the radius on aluminium, please call Dimond to discuss.

**Note 7:** DD630 Natural lighting sheets are not intended for use by themselves and must have support on the side lap from the steel sheet.

**Note 8:** Check suitability using section 2.1.3.1 - Table 2.1

N/R = Not recommended; N/A = Not available

$$\text{Curve Radius} = \frac{W^2 + 4(H)^2}{8H}$$

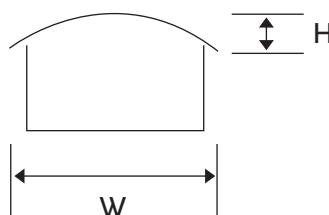

## COMPONENTS

For sheet materials, underlay, netting and fasteners refer to Section 2.2.

## 2.4.2.2.1

### CRIMP CURVED SHEETS

- Machine crimped across the profile pans. Each crimp deforms the sheet to a fixed angle and the radius required for the curve is achieved by altering the crimp spacing.
- G300 steel is generally used for 0.55mm thickness, although V-Rib and LT7® can be crimp curved in G550 steel.
- G550 steel is used for 0.40mm thickness in the Styleline, Hi Five, V-Rib and LT7® profiles to a maximum radius of 900mm. Larger radius curves have a risk of splitting the 0.40mm material due to fatigue at the crimps resulting from sheet deflection.
- H34 aluminium (5052 or 5251 alloys) in 0.90mm thickness is available for the Styleline, Hi Five and LT7® profiles.

## 2.4.2.2.2

### DRAPE CURVED SHEETS

Refer Section 2.2 for straight sheets.

## 2.4.2.2.3

### ROLL CURVED SHEETS

- G300 steel or H36 aluminium (5052 to 5251 alloys) in Corrugate profile is available to a minimum radius of 450mm and a maximum radius of 12m.
- Roll curved sheets are limited to a 4.5m tail length for ease of handling and transportation.

## 2.4.2.2.4

### CURVED FLASHINGS

Two-piece lock-seamed flashings are recommended to finish curved edges in a smooth line. Crimped flashings are not recommended for aesthetic reasons.

## INSTALLATION DETAILS

Installation recommendations for straight sheets apply together with the following additional requirements for all curved roofing systems.

### 2.4.2.3.1

## FRAMING AND FASTENERS

It is critical to the fitting and the final appearance of curved roofing that the purlin and/or girt framing is located true to line. The installer should not fit the sheeting to out-of-line members. A recommended tolerance from the true purlin alignment is  $\pm 5\text{mm}$ . The tighter the tolerance, the better the final appearance will be.

Dimond recommend fitting a trial crimped or roll curved sheet to the purlins before the order is run, to check the curve fits the framing. An allowance of an extra 2 weeks should be built into the lead time to allow for this.

For the Drape Curved Roof Systems the framing member stiffness and attachment to the primary structure and the sheet fasteners must be adequate to resist the loads induced by the force required to hold the sheets in place. All drape curved sheets should therefore be screw fixed. Fasteners for crimp curved as for straight sheets.

There shall not be any part of the curved roof section or any part of the roof that does not have fall, that could allow ponding to occur. This is critical at the top of curved sheets where the roof pitch is level. If necessary purlins may need to be closed up in this region to give support to the roof and avoid ponding.

On areas of curved roof below the profile minimum pitch, an additional 3mm thick (min) side lap seal tape or bead of silicone sealant should be applied continuously on the top of the underlap rib, before the next sheet is laid over the underlap rib.

Flashing must be fabricated and fitted to follow an even curve of the profile, without obvious humps.

### 2.4.2.3.2

## SHEET TERMINATION

Ends of sheets that are under head flashings and stop-ended must not terminate at zero or negative pitch. To ensure this does not occur it is recommended that the design is based on sheet termination at a roof pitch at least to the minimum pitch for the profile used.



## THERMAL INSULATION SYSTEMS

### PERFORMANCE

#### (a) Thermal Insulation Performance Statement

The performance of Dimond thermal insulation systems for roofing and wall cladding is covered by the statement for uninsulated systems together with the additional criteria set out below.

The use of Dimond metal roof or wall cladding in conjunction with foil underlay, Tasman Insulation NZ Building Insulation Blanket (BIB), or Foil Faced Building Insulation Blanket (FFBIB), can achieve thermal insulation with a reasonable expectation of performance to meet NZ Building Code requirements of:

- B2 – 50 years durability
- H1 – Energy efficiency

Design considerations must include:	Reference
Appropriate combination of foil underlay BIB and foil, or FFBIB to achieve the appropriate R value and light reflection.	2.4.3.1.1 (b), (c)
Allowance for thermal bridging – via purlins or girts – via skylights	
Use of the full thickness of insulation when laid between battens fixed onto purlins, rather than squeezing down onto purlin.	
Maintenance (and replacement if necessary) of the roof sheeting or wall cladding and fastener components.	

The performance is greatly affected by the quality of the installation which requires careful attention to detail to ensure gaps and holes through the insulation are eliminated as much as practicable.

When foil underlay is used as a vapour barrier all laps must be lapped 150mm and fully taped using 3M 425 foil tape 48mm wide.

BIB and FFBIB are designed for use at ambient temperatures and should not be used in conditions where the temperature exceeds 120°C (e.g. within 150mm of hot flues). The glass wool content of BIB and FFBIB will not burn.

Aluminium foil surfaces must not be exposed to continuous moisture contact, salt laden air, alkalines or contact with dissimilar metals, that will corrode the surface and reduce the insulation and light reflectance performance.

#### (b) Foil Selection

Reflective foils can be used to increase thermal insulation, reduce daytime heat gain, disperse light within the building, and provide a vapour barrier.

NZS 4200.1 Category								
Product Name	Duty	Reflective Surfaces		Vapour Barrier	Fire Retardant	Abrasion Resistant Surfaces		Self Supporting
		1	2			1	2	
Sisalation 450	Heavy	✓	✓	✓	✓	✓	✓	✓
Sisalation 430	Medium	✓	✓	✓	✓	✓	✓	
Sisalation 420 White Faced	Medium	✓	W	✓	✓	✓	✓	
Sisalation 420	Light	✓	✓	✓	✓	✓		
Sisalation 420 White Ink	Light	✓	W	✓	✓	✓		
Sisalation 120	Light	✓	✓	✓		✓		
Sisalation 120	Extra Light	✓	✓	✓		✓		

## COMPONENTS

### TASMAN INSULATION NZ BUILDING INSULATION BLANKET (BIB) AND FOIL FACED BIB (FFBIB)

#### Product Description

Glass Wool Building Insulation Blanket (BIB) and Foil Building Insulation Blanket (FFBIB) consist of long, fine glass wool fibres bonded together with a thermosetting resin to form a lightweight, flexible, blanket insulation. FFBIB is faced on one side with double-sided foil which is lightly adhered to the glass wool. BIB and FFBIB are available in stock sizes, but may be manufactured to special requirements.

#### Features and Benefits

- Saves energy by reducing ongoing running costs of the building
- Non combustible, offering a safer environment
- Foil facings save installation time
- Absorbs sound so reduces rain noise and other unwanted environment noise

Product	R Value	Thickness	Size (m)	Pieces	Area (m <sup>2</sup> )	Foil Facing
Pink Batts BIB R1.2	1.2	50	12 x 1.2	2	28.8	-
BIB R1.8	1.8	75	8 x 1.2	2	19.2	-
BIB R2.2	2.2	95	8 x 1.2	2	19.2	-
BIB R2.4	2.4	100	8 x 1.2	2	19.2	-
BIB R2.6	2.6	110	6 x 1.2	2	14.4	-
BIB R2.8	2.8	130	8 x 1.2	1	9.6	-
BIB R3.2	3.2	135	8 x 1.2	1	9.6	-
BIB R3.6	3.6	140	8 x 1.2	1	9.6	-
Flamestop FFBIB R1.2	1.2	50	12 x 1.2	1	14.4	Fire Retardant
FFBIB R1.8	1.8	75	12 x 1.2	1	14.4	Fire Retardant

For further information contact the manufacturer.

## NON FIRE RETARDANT FOIL

Sisalation Building Foils are a light duty, single sided reflective foil laminate recommended for use in commercial and industrial wall applications where the following are required:

- Low cost reflective inner facing
- Vapour barrier facing for building insulation blanket
- Non fire retardant

### Features and Benefits

Building foils provide a cost effective highly reflective surface to enhance interior light conditions, while providing low emissivity to limit heat loss and provide an effective barrier against water vapour entering the insulation and roof space when the laps are fully taped. Two way reinforced offering strength and with Albar on the reverse face offering a resistance to scuffing and abrasion.

### Applications

Product	Application
Sisalation 110	Extra light duty for economical wall applications, offering low strength resistance where abrasion is not critical
Sisalation 120	Light duty for wall applications, offering better strength and resistance to scuffing

## FIRE RETARDANT FOIL

Sisalation Fire Retardant Foils are a single side reflective foil laminate. Available in a light, medium and heavy duty laminate weight offering better resistance to exposure to wind as the duty increases.

Recommended for use in commercial and industrial wall and roof applications where the following are required:

- Effective reflective interior facing
- Vapour barrier facing for building insulation blanket
- Fire retardant non combustible material

### Features and Benefits

Fire retardant foils provide a highly reflective surface to enhance interior lighting conditions, while offering, in a fire situation, a non-combustible surface which will limit the spread of flame. The foil offers a low emissivity surface to limit heat loss and provide an effective barrier against water vapour entering the insulation and roof space when all the laps are full taped.

Two way reinforced for greater strength and edge tear. Albar surface on the reverse faces offers a better resistance to scuffing.

### Applications

Product	Application
Sisalation 420	A light duty fire retardant foil for economical wall applications when not exposed to high wind.
Sisalation 430	A medium duty fire retardant foil for wall applications and under roofs where better resistance to wind is required.
Sisalation 450	A heavy duty fire retardant foil for roof applications offering high strength in high wind conditions and best abrasion resistance. Suitable for high humidity applications such as indoor pools. Can be installed on spans up to 1200mm without netting or mesh support.

For further information contact the manufacturer.

## WHITE FACED FOIL

Sisalation White Faced Flame Retardant Foil laminates have a white face one side and an aluminium foil face the other. Available in a light duty white ink face or a medium duty white polybar film face.

Recommended for use as an attractive interior exposed lining where a light white fresh face is required under roofing and wall cladding, and where the following are required:

- Effective reflective interior facing
- Vapour barrier facing for building insulation blanket
- Fire retardant non-combustible material

### Features and Benefits

Provides a glossy white surface one side to diffuse and enhance lighting conditions, while offering in a fire situation a non-combustible surface which will limit the spread of flame. Both surface faces offer good scuff resistance and are two way reinforced which, combined with high tear resistance of the edges, limits damage during construction.

### Applications

Product	Application
Sisalation 420 WI	A light duty fire retardant foil with a white ink coating on one side. Recommended on walls where damage will be minimal during construction.
Sisalation 430 WF	A medium duty fire retardant foil with a white polybar film on one side. Recommended on roofs of warehouses and factories, but must be fully supported.

For further information contact the manufacturer.

## INSTALLATION INFORMATION

### a) Building Insulation Blanket (BIB) and Foil Faced BIB (FFBIB)

**Roofing** – Building Insulation Blanket (BIB) and Foil Faced BIB (FFBIB) are designed for use under any roof system which requires control of temperature loss or gain. FFBIB is a true vapour barrier which may be necessary for conditioned spaces. In these cases the lap may be sealed during installation. This may be accomplished using contact adhesive or a tape. A more practical solution for FFBIB is suggested using sealant/mastic. Wherever visible the foil reflects light creating a brighter environment below. Roofing underlay should always be placed on top of BIB, to avoid condensation from the roof underside wetting the BIB.

Where insulation is required to achieve its full R value it must not be laid over the purlins. Insulation must be laid between packers fixed onto the top of steel purlins with a 25mm air gap between roof and insulation. If this is not followed and the insulation is fixed over the top of the purlins and squashed down, the R value will be reduced. There is also a risk the roof will appear bumpy between fixings and the side laps will not fully fit together.

**Wall** – FFBIB is installed next to the external cladding (building paper should be placed between the cladding and the insulation) with the foil facing inward, the foil facing will reflect the light where it is visible.

Install the insulation system in a DRY state.

Butt adjacent edges of insulation tightly together and fill all gaps with offcuts to avoid heat leakage.

Fit insulation tightly around all roof penetrations and vent pipes except hot flues where a 150mm gap is required.

Where cutting is necessary use a sharp knife and a straight edge.

Where practical it is considered good practice to incorporate an air gap, for ventilation, between the insulation and the metal deck.

### b) Sisalisation Foil, Fire Retardant Foil and White Faced Foil

**Roofing** – Lay foil horizontally on netting. White faced foil is laid with the white surface facing down. Start at the gutter line and lap successive layers by 150mm minimum. For an effective vapour barrier seal all openings and laps with an appropriate 48mm adhesive foil tape, such as 3M 425 foil tape 48mm wide.

For vertical application lay the foil in the ridge to gutter direction with all laps a minimum of 150mm and sealed with an appropriate 48mm adhesive foil tape, such as 3M 425 foil tape 48mm wide.

**Walls** – Ensure foil is fixed to the supporting framing with a fastener system that is durable for at least 15 years. Lay and tape the laps as for roofing.

For further information visit [www.pinkbatts.co.nz](http://www.pinkbatts.co.nz)

## RAIN NOISE INSULATION SYSTEMS

### PERFORMANCE STATEMENT

The use of Tasman Insulation NZ Building Insulation Blanket (BIB) overlaid with a breather roofing underlay and in close contact with the underside of Dimond metal roofing can effectively reduce the surface impact noise from rainfall.

The noise reduction achieved has not been measured, but history of use suggests a noticeable reduction can be achieved. For the best results use either 75mm or 100mm BIB.

The effectiveness relies on correct installation whereby the supporting netting is stretched across the purlins to give a sag equivalent to one half of the blanket thickness. The BIB is consequently compressed by the roof sheeting over the total area.

Limitations of this system relate to the need for close contact between BIB and the roof underside and the consequences of a higher risk of corrosion from condensation or leakage moisture retained on the roof underside surface. Compression of the blanket will reduce thermal performance.

Other designed systems by acoustic engineers can be used such as:

- Building up a layer of 17.5mm plywood and insulation blanket laid over the purlins
- or
- Using imported specialist products to deaden the noise when laid under the roof, such as Wavebar Soundbaffle. It does add extra dead weight into the roof system, i.e. 8kg/m<sup>2</sup>, and is required to be fully sealed like a vapour barrier. For further information visit [www.soundguard.com.au](http://www.soundguard.com.au).

### Specification

Refer Thermal Insulation Section 2.4.3.1.

### COMPONENTS

Refer Thermal Insulation Section 2.4.3.1.2.

### 2.4.3.2.3 INSTALLATION

Refer Thermal Insulation Section 2.4.3.1.3.

## PERFORMANCE OF NATURAL VENTILATION

Natural ventilation of industrial and commercial buildings, or of the above ceiling roof space in air conditioned buildings, is a cost effective means of exhausting hot air or achieving a sufficient degree of air change in the building.

Natural ventilation should also be considered as a means of venting smoke in a fire situation, and as a means of helping to control condensation by removal of warm moist air from the building space.

The roof system can be designed to incorporate either a Dimond Fixed Ridge Ventilator or a series of Ampelair Turbo Ventilators. Design information is given in this section to enable estimation of exhaust airflow rate and hence a reasonable basis on which to design for the air changes required.



## DIMOND FIXED RIDGE VENTILATORS

### Exhaust Capacities

The table gives approximate exhaust flow capacities for a range of stack heights (ridge height above ground), wind speeds at the ridge and internal temperature between ground level and ridge.

Clear Throat Opening (mm)	Temperature Difference (°C)	Exhaust Flow litres/second/lineal metre					
		Stack Height (m)					
		5		10		15	
		Wind Speed (m/s)		Wind Speed (m/s)		Wind Speed (m/s)	
		1	5	1	5	1	5
150	5	60	190	80	195	90	200
	10	80	195	105	210	125	220
	15	90	200	125	220	150	235
300	5	120	380	160	390	180	400
	10	160	390	210	420	250	440
	15	180	400	250	440	300	470
450	5	180	570	240	585	270	600
	10	240	585	315	630	375	660
	15	270	600	375	660	450	705
600	5	240	760	320	780	360	600
	10	320	780	420	840	500	880
	15	360	800	500	880	600	940

Achievement of these flows requires sufficient openings to provide free airflow into the building.

Dimond Fixed Ridge Ventilators are available in Zinalume®, COLOURSTEEL™, ColorCote® and Aluminium material to match the roofing material chosen.

Reference to Section 2.1.3.3 should be made if dissimilar materials are used.

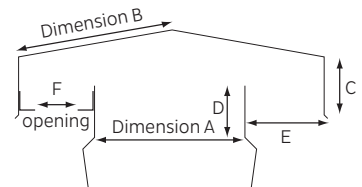
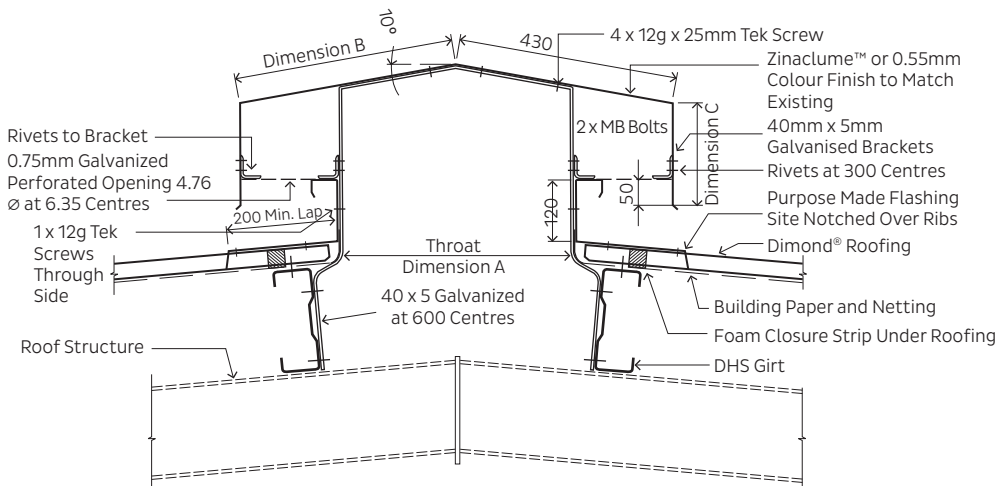

Dimensions

A	B	C	D	E	F
150	160	60	80	85	55
300	310	100	100	150	100
450	430	160	120	200	150
500	488	240	150	225	175
600	558	250	180	250	200

\*Hot dipped galvanized brackets (refer bracket selection table below for bracket size and sizing).

Sizes up to and including the 300 throat can be fixed directly onto the roof without bracketing using hex head self-drilling screws, the same as the roof profile on every rib. Sizes above this require a bracketing system.

U.L.S. Wind Load	Mild Steel Bracket Size (mm)	Maximum Bracket Spacing (mm)
1.0 kPa	40 x 5	600
2.0 kPa	40 x 8	600
3.0 kPa	40 x 8	400

U.L.S = Ultimate Limit Slate load

## AMPELAIR WIND DRIVEN VENTILATORS

- Locked-on rotor mechanisms prevents loss or damage in high winds.
- Corrugated vanes provide more strength and stability.
- Square to round base on all models.
- Sealed dual bearing system excludes dust, grit and other foreign matter and retains lubricant.
- Paint finish available to match roof selection.

Model		Throat Diameter (mm)
ZINACLUME™	Aluminium	
AS150	-	150
AS200	-	200
AS300	-	300
-	AA360	360
AS450	-	457
-	AA460	460
AS600	AA600	600



### Design Calculations for Ventilator Sizing

- Determine the volume of the building  
 Volume of section A =  $0/5 \times W \times H_a \times L$   
 Volume of section B =  $L \times W \times H_b$   
 Total building volume = volume of section B

**Note:** For factories, the combined volume A + B should be used.

Where Volume B is air-conditioned, only Volume A is used to calculate the number of ventilators required. No air should be drawn from the air-conditioned space. Using ventilators in ceiling space of air-conditioned buildings reduces the load on the air conditioning plant and helps reduce power consumption.

- Calculate the ventilator exhaust capacity required using:

$$EX = \frac{V \times AC}{3600N}$$

Where:

- V = volume of building or roof space, m<sup>3</sup>
- AC = air changes per hour
- EX = exhaust capacity of ventilator, m<sup>3</sup>/s
- N = number of ventilators

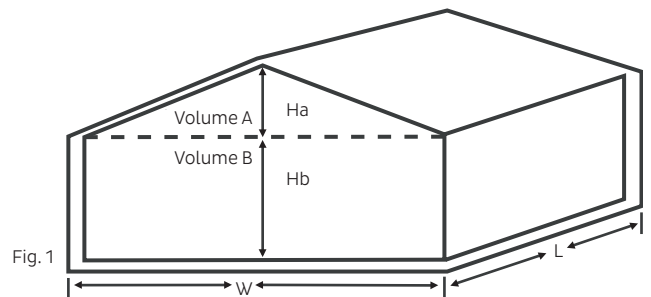

Select the ventilator size required from Table 2.4 (overleaf) given consideration of height above ground (stack height), wind speed, and temperature difference from floor level to ridge inside the building.

Consideration should be given to the space occupied by stored goods or machinery. The adjustment to volume can reduce the number of vents required up to 50%.

Continued on next page...

Table 2.4 Exhaust Capacity, m<sup>3</sup>/s

Stack Height Metres	Wind Speed m/s	Temp Diff °C	Throat Diameter in Millimetres					
			150	200	300	360	460	600
3	1.5	6	0.038	0.068	0.152	0.214	0.350	0.609
		12	0.039	0.070	0.158	0.221	0.362	0.630
		18	0.042	0.074	0.166	0.233	0.382	0.664
	5	6	0.084	0.150	0.336	0.472	0.772	1.343
		12	0.086	0.153	0.344	0.483	0.791	1.377
		18	0.088	0.157	0.352	0.494	0.808	1.408
5	1.5	6	0.039	0.070	0.158	0.221	0.362	0.630
		12	0.046	0.082	0.183	0.258	0.420	0.732
		18	0.047	0.084	0.189	0.264	0.431	0.751
	5	6	0.086	0.158	0.344	0.483	0.791	1.377
		12	0.089	0.158	0.354	0.497	0.813	1.414
		18	0.092	0.164	0.367	0.515	0.844	1.467
9	1.5	6	0.042	0.074	0.166	0.233	0.381	0.664
		12	0.047	0.084	0.180	0.264	0.431	0.751
		18	0.052	0.093	0.210	0.295	0.483	0.839
	5	6	0.088	0.157	0.352	0.494	0.808	1.408
		12	0.092	0.164	0.367	0.515	0.843	1.467
		18	0.093	0.166	0.371	0.522	0.855	1.486

### Specification

The Wind Driven Ventilators shall be Ampelair Model (**insert Model No.**) as supplied by Dimond and shall match the roof colour (or shall be in Standard Grey finish or shall be in Mill Finish – insert as appropriate). Installation shall be in accordance with the manufacturer's instructions and be done in a workmanlike manner.

## SAFETY SYSTEM PERFORMANCE

The provision of a permanent safe working environment throughout the roof installation (and for future maintenance work) can be achieved by using the Safety Mesh system over the entire roof plane.

Safety Mesh consists of 2mm galvanised wire with a tensile strength exceeding 450 MPa. The longitudinal wires are spaced at 150mm centres with crosswires spaced at 300mm centres. The rolls are 2100mm wide and are supplied in standard 50m rolls.

Safety Mesh complies with the “Safety Mesh requirements in the Approved Code of Practice for Safety in Working at Heights”, as published by the Occupational Safety and Health Service of the Labour Department.

Safety Mesh, securely fastened over the entire roof plane, eliminates the need to use harnesses, static lines, inertia reels or other safety equipment, except when working closer than 2m to the edge of the roof.

Safety Mesh has passed dynamic and static tests as required by AS/NZS 4389-1996.

The dynamic test has a 1500mm x 350mm, 165kg sand bag dropped from a height of 1400mm onto the mesh. The static test has a 350mm diameter probe pressed into the mesh with a force of 50 Newtons. To comply the sand bag or probe must not penetrate the mesh.

### Limitations On Use

- Do not use Safety Mesh for access or as a working platform.
- Workers should avoid walking or standing on Safety Mesh.
- It is not practicable to allow Safety Mesh to “sag” between purlins to accommodate insulation.
- For corrosive environments specifiers should consider PVC coated Safety Mesh.

2.4.5.2

## COMPONENTS

Safety Mesh complies with the following standards for mesh:

AS/NZS 4389-1996, Safety Mesh.

Architects or design engineers should specify Safety Mesh at the initial stage of any commercial or industrial project. For corrosive environments PVC coated Safety Mesh can be specified, refer Dimond for details.

## INSTALLATION OF SAFETY MESH

The fixing procedure is incorporated in a pamphlet included in every roll of Safety Mesh. Other pertinent installation details follow:

1. Take a continuous rope across the ridge; for this first pass workers MUST use appropriate fall protection equipment.
2. Position the rolls of mesh on mobile scaffolds either side of the roof and use the continuous rope to pull the mesh across the ridge.
3. Wires parallel to the direction of the corrugation of the sheeting (longitudinal wires) should be in contact with the tops of the purlins. Wires at right angles to the direction of the corrugations (transverse wires) shall be on top of the longitudinal wires.
4. Tie off to an anchor point the longitudinal wires of each "run" of mesh in accordance with one of the approved methods described in the pamphlet included in the roll. NB: The mesh is not safe until it is tied-off at each end. Anchor points can be 3mm diameter holes drilled into the steel purlin or 40mm long x 3.5mm diameter staples for timber purlins.
5. Side laps of the mesh MUST be lapped by one mesh spacing (150mm). If the purlin spacing is greater than 1700mm the side lap is to be twitched between purlins.
6. All wire joints MUST be twisted four times.
7. End joins should be avoided, but can be used provided the procedure in the Safety Mesh pamphlet is carefully followed.