

## DIMOND LT7® & LT5 PROFILE INFORMATION

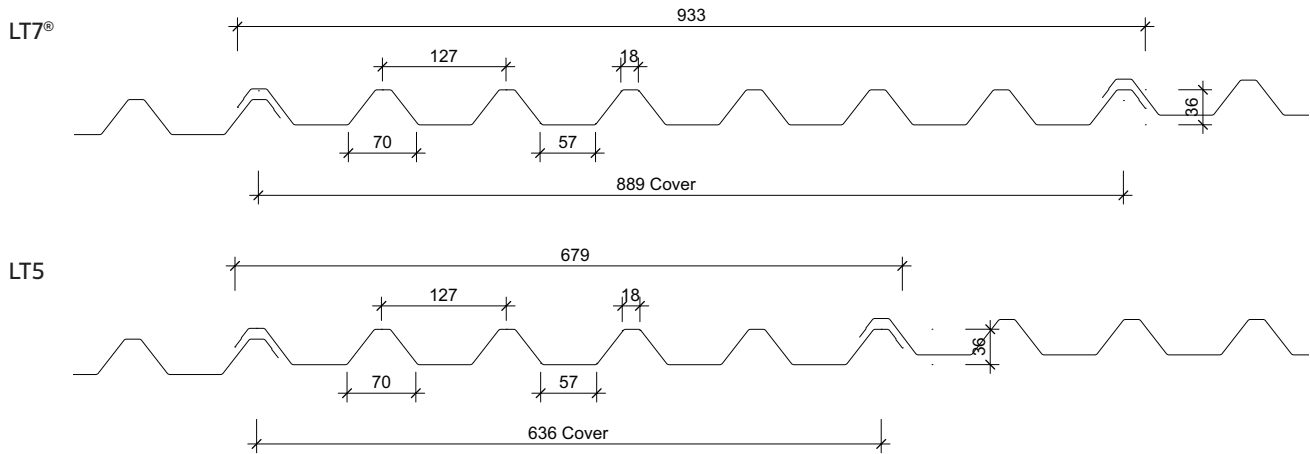

	LT7®	LT5
Cover (mm)	889	635
Sheet width (mm)	933 (Wellington) 942 (Invercargill)	725
Minimum Pitch	3° (approx. 1:20)	

All dimensions given are nominal

### Sheet Tolerances

Sheet width:  $\pm 5$ mm

Sheet width for aluminium +0, -15mm. If sheet cover widths are critical, advise Dimond® Roofing at time of order.

Sheet length: +10, - 0mm. For horizontal wall cladding where notified at time of order of intended use, tighter tolerances can be achieved +3, -0.

Material Options	Steel		Aluminium		Steel		Aluminium	
	LT5		LT5		LT7®		LT7®	
Thickness (BMT) mm	0.40	0.55	0.70	0.90	0.40	0.55	0.70	0.90
Nominal weight/lineal metre (kg/m)	3.17	4.27	1.78	2.28	4.12	5.55	2.31	2.96
Drape curved roof - min. radius (m)	80	50	80	50	80	50	80	50
Purlin spacing's for drape curved roof (m)(1)	1.4	2.2	1.4	2.2	1.4	2.2	1.4	2.2
**Machine curved - roof min. radius (mm)	n/a	n/a	n/a	n/a	900	400	n/a	400
Unsupported overhang (2)(mm)	250	350	200	300	250	350	200	300

(1) Recommended maximum purlin spacing's at minimum radius.

(2) Based on 1.1kN point load support, but not intended for roof access.

n/a not available

Roll-forming facilities at: Wellington and Invercargill

\*\* Crimp Curving facility at: Wellington

Sheet lengths: LT7® and LT5 are custom run to order. Where long sheets are used, consideration must be given to:

- Special transportation licences for sheet lengths over 25m
- Site access for special lifting equipment
- Fixing techniques to accommodate thermal expansion

## LT7® - LT5 LIMIT STATE LOAD/SPAN CAPACITY CHART

(span in mm, distributed serviceability loads in kPa)

### Serviceability Category

		Unrestricted-Access Roof	Restricted-Access Roof			Non-Access Roof or Wall		
G550 Steel 0.40mm	End Span (mm)	800	900	1000	1200	1300	1500	1800
	Internal Span (mm)	1200	1300	1500	1800	1900	2300	2700
	Serviceability	2.5	2.2	2.1	1.7	1.6	1.1	0.8
G550 Steel 0.55mm	End Span (mm)	1300	1400	1700	1900	2000	2300	2500
	Internal Span (mm)	2000	2100	2500	2900	3000	3400	3800
	Serviceability	2.2	2.1	1.8	1.5	1.4	1.2	1.1
5052, H36 Aluminium 0.70mm	End Span (mm)				900	900	1100	1400
	Internal Span (mm)				1300	1400	1700	2100
	Serviceability				1.7	1.6	1.3	0.9
5052, H36 Aluminium 0.90mm	End Span (mm)	1100	1100	1300	1500	1600	1900	2100
	Internal Span (mm)	1600	1700	2000	2300	2400	2800	3200
	Serviceability	2.3	2.3	2.1	1.7	1.6	1.2	0.9
Duraclad® 1.7mm (Note 4)	End Span (mm)			600	800	900	1100	1400
	Internal Span (mm)			900	1200	1300	1700	2100
	Ultimate			4.5	4.5	4.5	2.7	1.7

#### Notes

- In any category, spans above the maximum shown should not be used. Category 1 and 2 maximum spans are based on static point load testing as a guide, and further limited by practical experience of roof performance under dynamic foot traffic loads. Category 3 maximum spans are limited as a guide to achieving satisfactory appearance for wall cladding.
- Loads given are based on 4 screw fasteners/sheet/purlin.
- Loads given are limited to a maximum of 3.5kPa. If design requirements exceed this limit, Contact Dimond® Roofing for specific advice.
- Duraclad®
  - Serviceability Limit State Load are not applicable to Duraclad® material, as it does not experience permanent deformation
  - System must include Safety Mesh if intended for use as a Restricted-Access roof. Refer Section 2.2.1.8
- N/R = not recommended
- End span capacities given in this table are based on the end span being 2/3 of the internal span.
- Design Criteria for Limit State Capacities**
  - Serviceability Limit State**  
No Deflection or permanent distortion that would cause unacceptable appearance, side lap leakage or water ponding, due to foot traffic point loads, inward or outward wind loads or snow loads.
  - Ultimate Limit State**  
No pull through of fixings or fasteners withdrawal resulting in sheet detachment due to wind up-lift (outward) loads.
- System Design**  
The span capacity of LT7®/5 is determined from the LT7®/5 Limit State Load/Capacity Chart using the section of the chart appropriate to grade and type of material, and to the category of serviceability selected from the three categories below. Serviceability loads have been derived by test to the NZMRM testing procedures. To obtain an ultimate limit state load we recommend factoring the serviceability load up by 1.4 in-line with NZMRM guidelines. The capacities given do not apply for cyclone wind conditions.
 

**Serviceability Requirements**  
While these categories are given for design guidance to meet the serviceability limit state criteria, foot traffic point load damage may still occur if there is careless placement of these point loads.

Service Category	Description
1. Unrestricted-access roof	Expected regular foot traffic to access the roof for maintenance work and able to walk anywhere on the roof. No congregation of foot traffic expected.
2. Restricted-access roof	Expect occasional foot traffic educated to walk only on the purlin lines, in the profile pan. Walkways installed where regular traffic is expected, and "Restricted Access" signs placed at access point.
1. Non-access roof or wall	Walls or roofs where no foot traffic access is possible or permitted. If necessary, "No Roof Access" signs used.
- Wind Pressure Guide**  
As a guide for no-specific design the following S.L.S. design loads in accordance with the MRM Roofing Code of Practice can be used for buildings less than 10m high, otherwise AS/NZS 1170.2 should be used  
Low wind zone = 0.68kPa, Medium wind zone = 0.93kPa, High wind zone = 1.32kPa, Very high wind zone = 1.72kPa and Extra high wind zone = 2.09kPa.

## LT7®/5 Design

LT7®/5 should be screw fixed to either timber or steel purlins. The use of the appropriate length of 12g or 14g screw will ensure failure by screw pull out will not occur under loads within the scope of the Limited State Load/Span Capacity Chart.

## LT7®/5 Fastener Designation

Fixing Requirement				
Purlin or frame material	Roof		Wall (over vented cavity batten, 18 - 25mm thick)	
	Base material		Base material	
	Steel	Aluminium	Steel	Aluminium
Timber	Type 17 14g x 75mm Timbertite	14g x 73mm Alutite	Type 17 12g x 50mm Timbertite	14g x 55mm Alutite
Steel	Tek 12g x 68 or 14g x 65	Stainless Steel grade 304 14g x 75mm	M6 x 50mm roofzip	Stainless Steel grade 304 14g x 20mm

\*If sarking or insulation is used over the purlins or for wall cladding fixing onto cavity a batten, into a stud, the screw length will need to be increased.

When using Stainless Steel screws, an 8mm diameter clearance hole must be drilled through the Aluminium LT7 sheet and an EPDM seal with an Aluminium washer must be used.

For screw size range and fastener/washer assembly refer to Section 2.2.3.1

The Limited State Load/Span Capacity Chart for LT7® is based on 4 screw fasteners/sheet/purlin without the use of load spreading washers. For LT5 Load /span capacity chart is based on 3 screw fasteners/sheet/purlin without the use of load spreading washers.

Profile metal washers are recommended for use:

1. On end spans, or large internal spans where Ultimate Limit State distribution load is limiting. Contact Dimond® Roofing for specific advice in these cases.
2. When required to enable the fixing system to accommodate the thermal movement of long sheets – See Section 2.1.3.4 Thermal Movement.
3. Whenever the designer wishes to ensure the risk of fastener over-tightening will not cause dishing in the crest of the profile rib.

Use in serviceability categories (1) and (2) can allow the reduction of fasteners to 3 screw fasteners/sheet/purlin. If this is done, the distributed load capacities given in the chart should be reduced using a multiplying factor of 0.75.

Long spans may require specification and use of side lap stitching screws – Section 2.3.2 C Installation

Information: Layout and Fastenings.

## Design Examples

Restricted access roof, 0.55mm G550 steel LT7® has a maximum end span of 1900mm and a maximum internal span of 2900mm. The following distributed load capacities apply.

	4 fasteners/sheet	3 fasteners/sheet
End Span	1900mm	1900mm
Internal Span	2900mm	2900mm
Serviceability	1.5kPa	1.1kPa

### LT7® Fastener Layout Options

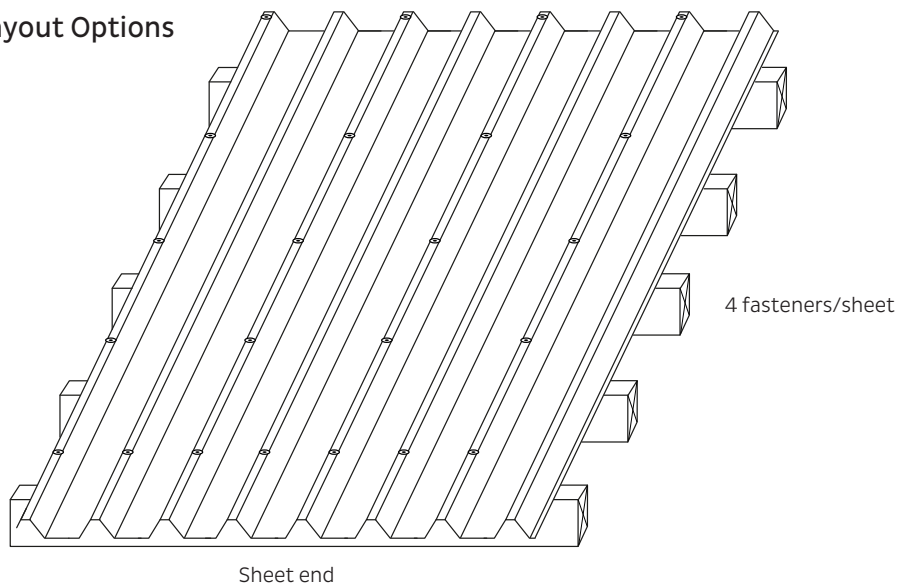

### LT7® Fastener Layout Options

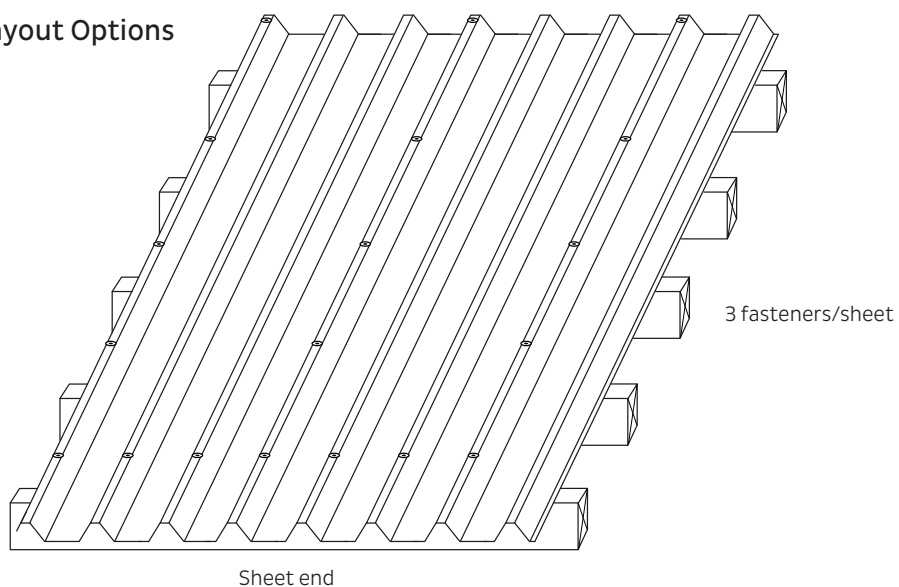

### LT5 Fastener Layout Options

