

DIMOND EUROTRAY® ROLL CAP PROFILE INFORMATION

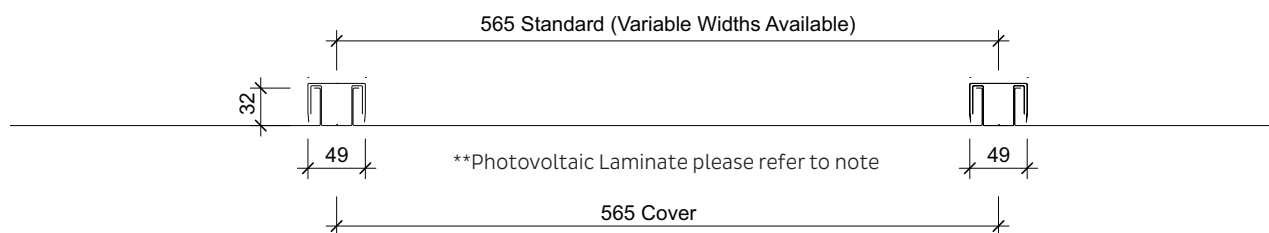

Roll-forming facility	AKL	CHC	INV
Cover (mm)	575	565	579
Sheet width (mm)	540	530	544
Minimum Pitch	5° (approx. 1:11)		

Note for Copper and Zinc reduce widths by 10mm

Sheet Tolerances

Sheet width: ±5mm

Sheet width for aluminium +0, -15mm. If sheet cover widths are critical, advise Dimond® Roofing at time of order.

Sheet length: +10, - 0mm. Tighter tolerances can be achieved +3, -0.

Material Options	Steel	Aluminium
Thickness (BMT) mm	0.55	0.90
Nominal weight/lineal metre (kg/m)	2.77	1.48
Drape curved roof - min. radius (m)	n/a	n/a
Substrate required	Yes	Yes
Vented Underlay Required (e.g. Tyvek Metal)	Yes	Yes
Machine curved - roof min. radius (mm)	n/a	n/a
Drip edge flashing required see detail R-005-02	Yes	Yes

Roll-forming facilities at: Auckland, Christchurch and Invercargill

Curving facilities: Machine is transportable
For curving restraints check with the local RoofingSmiths.

Sheet lengths: Eurotray® is custom run to order. Where long sheets are used, consideration must be given to:

- Special transportation licences
- Should be run on-site
- Site access for special lifting equipment
- Fixing techniques to accommodate thermal expansion

This roofing system is to be installed by RoofingSmiths.

**NOTE

Photovoltaic laminates (PVL's) can be installed on to this profile at an additional cost when the cladding is completed and other trade have finished or it can be installed at a later date.

Laminates are 348mm wide and available in 5.910mm and 2.585mm lengths. Lead time of 16 weeks

Laminates cannot be installed on raking sections of roofs

Consult with Dimond® Roofing 0800 Dimond (0800 346 663) for further information

Can be installed as a vertical wall cladding only with a substrate over vented cavity battens.

OIL CANNING: Oil Canning is the visible waviness in the flat areas of metal roofing and walling. Oil canning produces an aesthetic effect inherent in standing seam tray profiles and profiles/flashings with wide flat elements. It does not cause detriment to product performance.

Oil canning can occur during the forming and installation processes and during thermal expansion of the roof sheeting during its life cycle. The effect can be more or less pronounced depending on **differing light and sun angle conditions and the coating gloss levels.**

For fully supported standing seam tray profiles, oil canning can be reduced by the vented roof underlay (e.g. Tyvek Metal), in addition backer rods under the tray can also be used. There are several options to reduce the oil canning effect in tray type profiles and flashings, for example, a) increasing the thickness of the material, b) using stiffening swages in wide flat elements and c) limiting flat elements to less than 150mm width. For further information, please refer to the New Zealand Metal Roof and Wall Cladding Code of Practice, Section 12.3.

Eurotray® Roll Cap Design

Eurotray® Roll Cap roof cladding must always be installed over a plywood (12mm minimum) substrate with a moisture content of less than 18% and made wind tight, with purlin supports underneath at 600mm centres in low to high wind zones and 400mm centres for very high and extra high wind zones. 8g x 40mm countersunk stainless steel screws at 150mm centres around the panel edged and 200mm centres on the intermediate supports. The fasteners should be no closer than 10mm to the edge.

A 3mm expansion gap should be provided between the sheets. All joints should be staggered and taped over before placing underlay, Dimond® Roofing recommend the use of vented type underlay such as Tyvek metal or Covertek 403 with drainage mat. This allows added air-flow between the underside of the tray and substrate, it also helps to reduce oil-canning in the tray.

Fasteners that are used to secure Eurotray® down as a roof cladding must penetrate through the substrate and into the purlin a minimum of 30mm for timber and 6mm for steel purlins. For wall cladding the fasteners must be long enough to pass through the substrate, cavity batten and into the main frame by 30mm for timber and 6mm for steel.

Clip Fixing Requirement - 1 fixing per clip per purlin								
Purlin or frame material	Roof (standard 12mm Substrate)				Wall (over vented cavity batten, 18 - 25mm thick)			
	Base material				Base material			
	Steel	Aluminium	Copper	Zinc	Steel	Aluminium	Copper	Zinc
Timber	Type 17 class 4 12 x 50mm timbertite	Type 17 class 4 12 x 50mm timbertite	N/A	N/A	Type 17 class 4 12 x 65mm timbertite	Type 17 class 4 12 x 65mm timbertite	N/A	N/A
Steel	Class 4 12 x 45mm steeltite	Class 4 12 x 45mm steeltite	N/A	N/A	Class 4 12 x 45mm steeltite	Class 4 12 x 45mm steeltite	N/A	N/A

Design

Fasteners must be fixed closer together on the periphery edges of all roofs in areas of High to Extra High Wind Zones.

Unlike profiled metal cladding, the point load imposed on a fully supported cladding is supported by the substrate underneath.

Clip fixing table	
Wind Zone	Purlin Centre (mm)
Low to High	600
Very High to Extra High	400

Minimum pitch for Eurotray® Roll Cap is 5 degrees.

NOTE

Flashing and jointing details when using Copper or Zinc materials are required to be solder, silicone sealants are not to be used on these materials.

Eurotray® Roll Cap (over substrate)

400mm purlin centres
Very high/Extra High Wind Zones

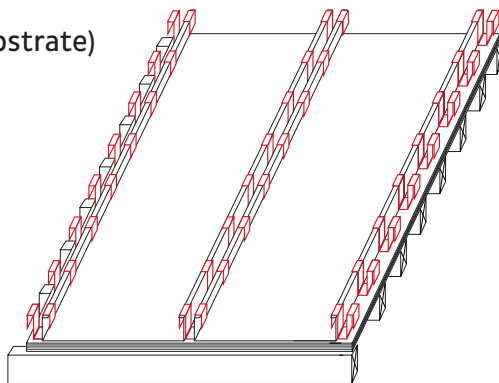

Eurotray® Roll Cap (over substrate)

600mm purlin centres
Low - High Wind Zones

